

GIRA

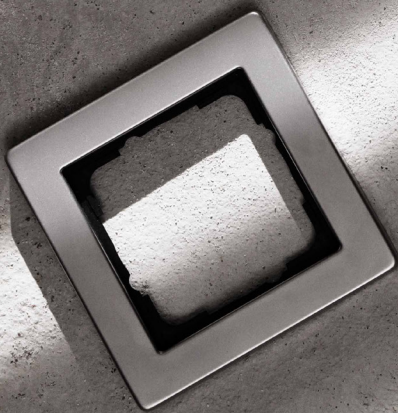







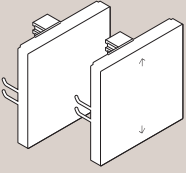
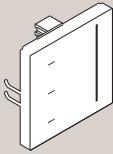
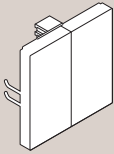
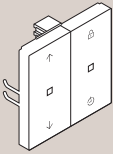

System basics / 07 / Gira System 3000

2nd extended reprint

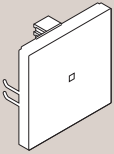
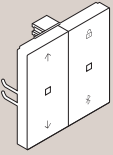
Gira System 3000 / Device overview

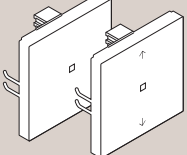
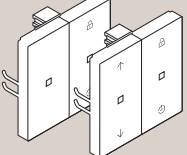
Top units

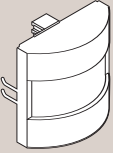
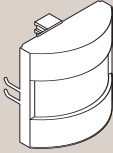
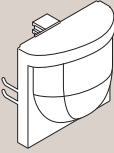
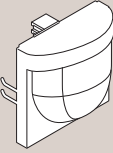
Inserts

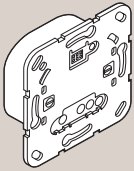
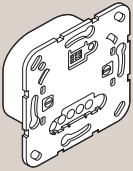
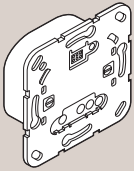
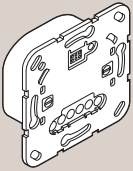
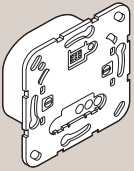
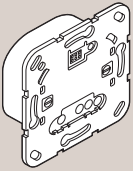
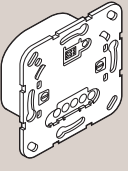
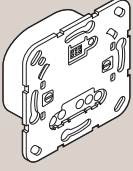
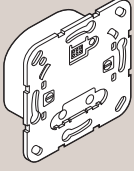
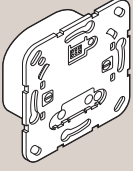
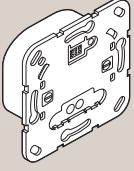
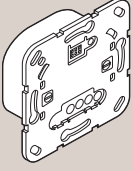
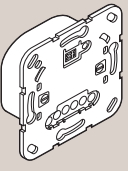
 <p>Gira System 3000 operating top unit and operating top unit arrow symbols</p>	 <p>Gira System 3000 touch top unit</p>	 <p>Gira System 3000 operating top unit, 2-gang</p>	 <p>Gira System 3000 operating top unit Memory arrow symbols</p>	 <p>Gira System 3000 blind timer and timer Display</p>	 <p>Gira System 3000 operating top unit BT</p>
 <p>Gira System 3000 blind timer and timer BT</p>	 <p>Gira System 3000 room temperature controller Display</p>	 <p>Gira System 3000 room temperature controller BT</p>	 <p>eNet wireless operating top unit arrow symbols/operating top unit</p>	 <p>eNet wireless operating top unit Memory arrow symbols/Memory</p>	 <p>Gira System 3000 brightness and temperature sensor BT</p>
 <p>Gira System 3000 motion detector top unit 1.10 m Standard</p>	 <p>Gira System 3000 motion detector top unit 1.10 m Komfort BT</p>	 <p>Gira System 3000 motion detector top unit 2.20 m Standard</p>	 <p>Gira System 3000 motion detector top unit 2.20 m Komfort BT</p>	 <p>Gira System 3000 presence and motion detector 360° top unit BT</p>	
 <p>Gira System 3000 relay switching insert</p>	 <p>Gira System 3000 relay switching insert, 2-gang</p>	 <p>Gira System 3000 electronic switching insert</p>	 <p>Gira System 3000 room temperature controller insert with sensor connection</p>	 <p>Gira System 3000 universal LED dimming insert Standard</p>	 <p>Gira System 3000 universal LED dimming insert Komfort</p>
 <p>Gira System 3000 universal LED dimming insert Komfort, 2-gang</p>	 <p>Gira System 3000 DALI Power control unit flush-mounted insert</p>	 <p>Gira System 3000 2-wire auxiliary insert</p>	 <p>Gira System 3000 3-wire auxiliary insert</p>	 <p>Gira System 3000 impulse insert</p>	 <p>Gira System 3000 blind control insert without auxiliary input</p>
 <p>Gira System 3000 blind control insert with auxiliary input</p>					

System basics

07

Gira System 3000

// Table of Contents

1 //	Gira System 3000	11
1.1	Easy installation	11
1.2	Intuitive operation	12
1.3	Clear advantages	12
<hr/>		
2	Application scenarios	13
2.1	Single-family home	13
2.1.1	Hands-free lighting	14
2.1.2	Alarm function	14
2.1.3	Automatic lighting for the guest WC	15
2.1.4	Lighting and fan for the guest WC	15
2.1.5	Lighting, fan and radio for the bathroom	16
2.1.6	Convenient lighting control with an auxiliary unit	16
2.1.7	Dimming both spotlights with an auxiliary unit	17
2.1.8	New operating points	17
2.1.9	Shading entire areas using group control	18
2.1.10	Automatic shading in bright sunlight	18
2.1.11	Lock-out protection	19
2.1.12	Presence simulation	19
2.1.13	Scene for a cosy TV evening	20
2.2	Commercial properties	21
2.2.1	Daylight-dependent lighting control in the entrance area	22
2.2.2	Automatic staircase lighting	22
2.2.3	Lighting and shading as required in the conference room	23
2.2.4	Individual presence detectors with continuous light function	23
2.2.5	Semi-automatic light with energy-saving function	24
2.2.6	Display window	24
2.2.7	Switching restaurant lights centrally	25
2.2.8	Hotel corridor – Check in and feel welcome	25
<hr/>		
3	Device overview	26
3.1	Top units and inserts	27
3.2	Combination options for lighting and blind control	29
3.3	Combination options for lighting, blind and heating control	31
3.4	Auxiliary units	32
3.4.1	3-wire auxiliary insert with motion detector	33
3.4.2	3-wire auxiliary insert with brightness evaluation	33
3.4.3	Central 3-wire auxiliary insert (group control)	34
3.5	Misplacement protection	34
3.6	Backward compatibility	34
<hr/>		
4.	System 3000 Lighting	35
4.1	Device overview	35
	System 3000 relay switching insert	36
	System 3000 relay switching insert, 2-gang	36
	System 3000 electronic switching insert	37
	System 3000 impulse insert	37
	System 3000 universal LED dimming insert Standard	38
	System 3000 universal LED dimming insert Komfort	38
	System 3000 universal LED dimming insert Komfort, 2-gang	39
	System 3000 DALI Power control unit, flush-mounted insert	39
	System 3000 universal LED dimmer Mini	40
	System 3000 universal LED rotary dimming insert Standard	40
	System 3000 universal LED rotary dimming insert Komfort	41
	Gira System 3000 3-wire rotary auxiliary insert for LED dimmer	41
	System 3000 2-wire auxiliary insert	42
	System 3000 3-wire auxiliary insert	42
	System 3000 universal LED dimmer DRA	43
	System 3000 universal LED power booster DRA	43
	System 3000 motion detector top unit 1.10 m Standard	44
	System 3000 motion detector top unit 2.20 m Standard	45
	System 3000 motion detector top unit 1.10 m Komfort BT	46
	System 3000 motion detector top unit 2.20 m Komfort BT	47

	System 3000 presence and motion detector 360° top unit BT	48
	System 3000 operating top unit	48
	System 3000 operating top unit arrow symbols	48
	System 3000 operating top unit, 2-gang	49
	System 3000 operating top unit Memory arrow symbols	49
	System 3000 blind timer and timer Display	50
	System 3000 blind timer and timer BT	50
	System 3000 operating top unit BT	51
	System 3000 eNet wireless operating top unit	51
	System 3000 eNet wireless operating top unit arrow symbols	51
	System 3000 eNet wireless operating top unit Memory	52
	System 3000 eNet wireless operating top unit Memory arrow symbols	52
4.2	Switches and buttons	52
4.2.1	Components	52
4.2.2	Definitions	53
4.2.3	Switch as main and auxiliary units	54
4.2.4	Mounting and settings	54
4.3	Dimming	57
4.3.1	Components	58
4.3.2	Mounting and settings	59
4.3.3	Dimmability of light sources	60
4.3.4	Dimming principles	61
4.3.5	Installation-related power reduction	62
4.3.6	Setting the operating mode and basic brightness	63
4.3.7	DALI	65
4.3.8	Tips for planning LED light dimmers	66
4.3.9	Troubleshooting	67
4.4	Automatic lighting	69
4.4.1	Components	69
4.4.2	Operation and functions	70
4.4.3	Setting up detection fields	73
4.4.4	Settings	74
4.4.5	Motion detector top unit Standard and relay switching insert, 2-gang	75
4.4.6	Motion detector top unit Komfort BT and relay switching insert, 2-gang	76
4.4.7	Pairing the motion detector top unit Komfort Bluetooth with mobile end devices	76
<hr/>		
5	System 3000 Shading	71
5.1	Device overview	77
	System 3000 blind control insert without auxiliary input	77
	System 3000 blind control insert with auxiliary input	78
	System 3000 operating top unit	78
	System 3000 operating top unit arrow symbols	78
	System 3000 touch top unit	79
	System 3000 operating top unit Memory arrow symbols	79
	System 3000 blind timer and timer Display	80
	System 3000 operating top unit BT	80
	System 3000 blind timer and timer BT	81
	eNet wireless operating top unit Memory	81
	eNet wireless operating top unit Memory arrow symbols	81
	eNet wireless operating top unit	82
	eNet wireless operating top unit arrow symbols	82
	System 3000 brightness and temperature sensor BT	82
5.2	Electrical connection	83
5.2.1	Connecting the insert	83
5.2.2	Requirements of the shading motor	84
5.3	Tips for operation	84
5.3.1	Adjusting hangings and slats	84
5.3.2	Blocking function	84
5.3.3	Ventilation position	84
5.3.4	Reversal time	84
5.3.5	Setting the ventilation position	85
5.4	Control options	83
5.4.1	Individual control	83
5.4.2	Group and central control	86

5.4.3	Central control	86
5.4.4	Connecting auxiliary units	88
5.4.5	Integrating the device into group control	88
5.4.6	Connecting the wind sensor	89
5.5	Functionality depending on the top unit	89
5.6	Hanging types	92
5.6.1	Selection of the top unit	92
5.7	Wind alarm	93
5.7.1	Wind sensor	93
5.7.2	Wind sensor Standard	93
5.7.3	Central wind alarm	94
5.8	Sun protection function	95
5.8.1	Top units for the sun protection function	95
5.8.2	Brightness and temperature sensor BT	96
5.8.3	Brightness and temperature sensor BT	96
5.8.3	eNet wireless sun sensor Solar	96

6	Heating, ventilation, room climate	97
6.1	Device overview	97
	System 3000 relay switching insert	97
	System 3000 electronic switching insert	98
	System 3000 room temperature controller insert with sensor connection	98
	System 3000 room temperature controller Display	99
	System 3000 room temperature controller BT	99
	System 3000 brightness and temperature sensor BT	100
	System 3000 remote sensor	100
6.2	Application scenarios for room temperature control	101
6.2.1	Floor heating, hydronic, without temperature limitation	101
6.2.2	Floor heating, hydronic, with temperature limitation	101
6.2.3	Floor heating, electric, without temperature limitation	102
6.2.4	Floor heating, electric, without temperature limitation	102
6.2.5	Floor temperature control	103
6.2.6	Temperature detection with external brightness and temperature sensor BT	103
6.3	Electrical connection	104
6.3.1	Connecting the insert	104
6.4	Functional description	105
6.4.1	Overview of programming menu and button combinations	106

7	Gira Bluetooth App	107
7.1	Structure of the user interface	107
7.2	Navigation bar	108
7.3	Action area	108
7.3.1	Tile view	108
7.3.2	Detailed view	109
7.4	Settings in the system menu	110
7.4.1	View Configuration	111
7.4.2	Select Home	111
7.5	Devices	111
7.5.1	Pairing devices	112
7.5.2	Unpairing devices	112
7.5.3	Assigning a coupling PIN	113
7.5.4	Assigning a device PIN	113
7.5.5	Lost PIN number	114

8	Operation	115
8.1	Manual control	115
8.1.1	Operating top unit	115
8.1.2	Operating top unit Memory, eNet wireless operating top unit Memory	117
8.2	Automatic control	119
8.2.1	Blind timer and timer Display	119
8.2.2	Operating top unit BT	121
8.2.3	Blind timer and timer BT	123
8.4	Operation using auxiliary units	125
8.4.1	Rocker button as an auxiliary unit	125
8.4.2	Auxiliary unit with operating top unit	125
8.5	Time-switch function	126
8.5.1	Switching times	127
8.6	Astro function	127
8.7	Presence simulation	128
8.8	Alarm function	128

1 // Gira System 3000

With the new System 3000, everyday control of lighting, shading and heating is easier and more convenient than ever before. By combining different top units and inserts, the kit offers a solution for almost any desired function. System 3000 can be controlled manually on the device, automatically via sensors and/or a timer, or using the Gira System 3000 App. The tradesperson-friendly inserts have a low installation depth, which makes them easier to mount and shortens installation times. All System 3000 inserts can be freely combined with Gira top units from the Standard 55, E2, E3, Event, Esprit, Studio, ClassiX, and F100 design lines and with some Gira TX_44 top units.

1.1 Easy installation

Installing the System 3000 components is now easier than ever. The low installation depth of the inserts offers more space for wiring. The galvanised steel support plate creates sufficient stability. The housed mounting claws enable simple and quick installation and ensure a secure hold in the flush-mounted device box.

The space-saving inserts can be effortlessly wired into any commercially-available flush-mounted device box and cavity wall box.

The new inserts make it possible to check the installation with a test button even without top units. You can also make additional settings using the test button. An LED gives feedback on the function currently set.

Start-up is particularly reliable thanks to the plug-in top units with particularly sturdy retaining springs. A misplacement protection feature indicates by LED or via the display if the top unit has been placed on the wrong insert, for example after a renovation.

Mounting the cover frames and top units is particularly easy thanks to sturdy support plates and retaining springs. A misplacement protection feature helps to find the right insert after a renovation.

After successful installation, the top unit with all its functions is available.

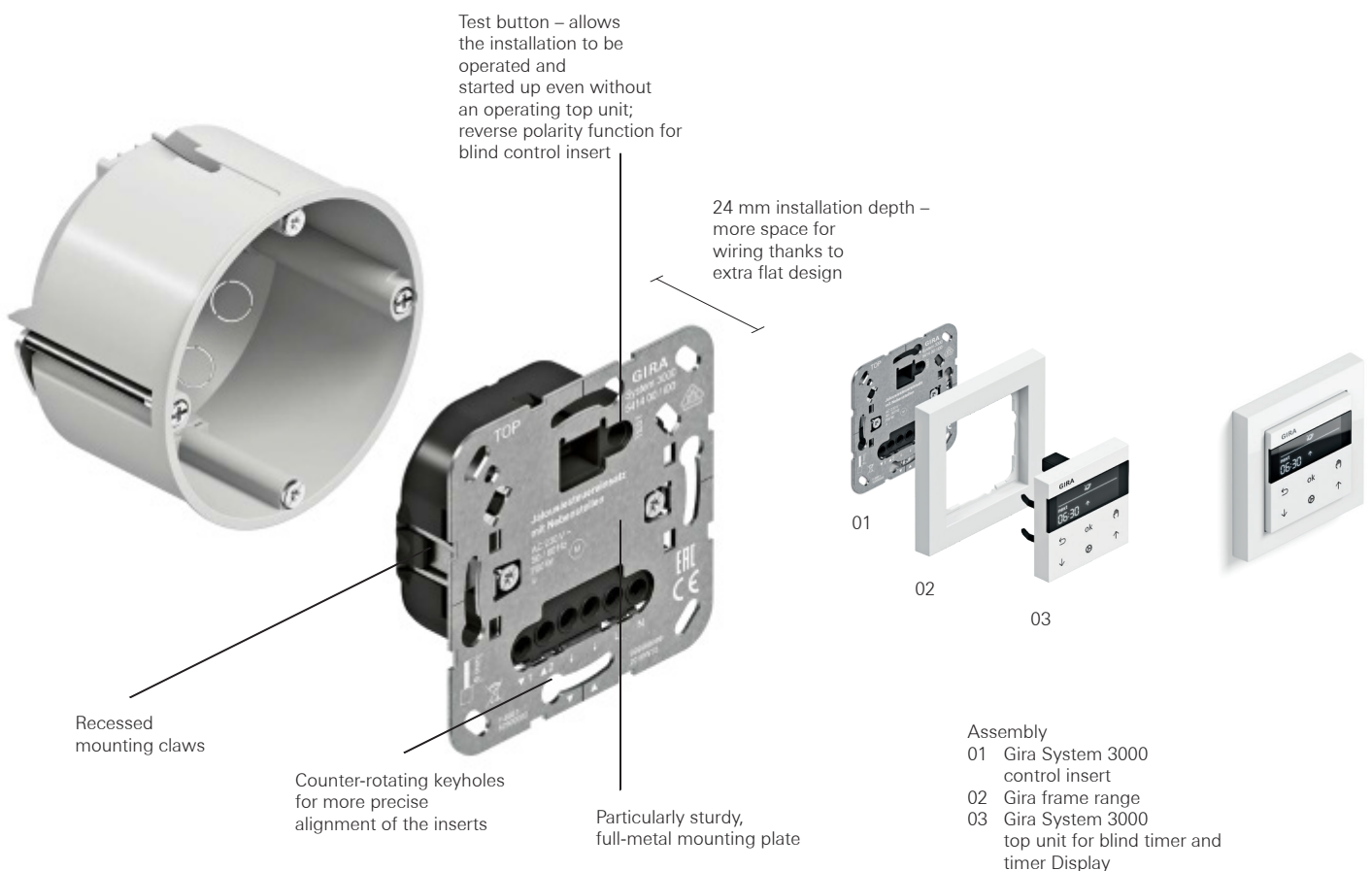

1.2 Intuitive operation

Besides manual operation, the Bluetooth components of the new System 3000 can be conveniently operated and configured from a smartphone using the Gira System 3000 App.



1.3 Clear advantages

System 3000 supports skilled tradespeople as well as building contractors and renovators with its modular design concept.

Skilled tradespeople
Growing, future-proof system creates customer loyalty.
Easy and fast installation, e.g. reverse polarity function with blind control insert.
Backwards compatible with the addition of existing systems.
Test button and operating mode selection button shorten the installation time.
Voltage measurement possible when installed.

Building contractors and renovators
Components for different applications (switching, dimming, shutters, blinds, heating control, etc.).
Easy and intuitive operation for all age groups.
Control using Gira System 3000 App possible as an option.
Use of Bluetooth technology, so a separate WLAN is not required.
Colour and material of the top units can be selected from the extensive Gira design line.
All inserts can be freely combined with Gira top units from the Standard 55, E2, E3, Event, Esprit, Studio, ClassiX, and F100 design lines and with some Gira TX_44 top units.
Low installation effort saves time and money.
Depending on the operating top unit, the power consumption in standby is only 0.2 to 0.5 W.
Backward compatibility with the addition of existing systems, blind control and System 2000.

2 // Application scenarios, lighting and blinds

2.1 Single-family home

Note:

Application scenarios for room temperature control can be found in Section 6.2 on page 101

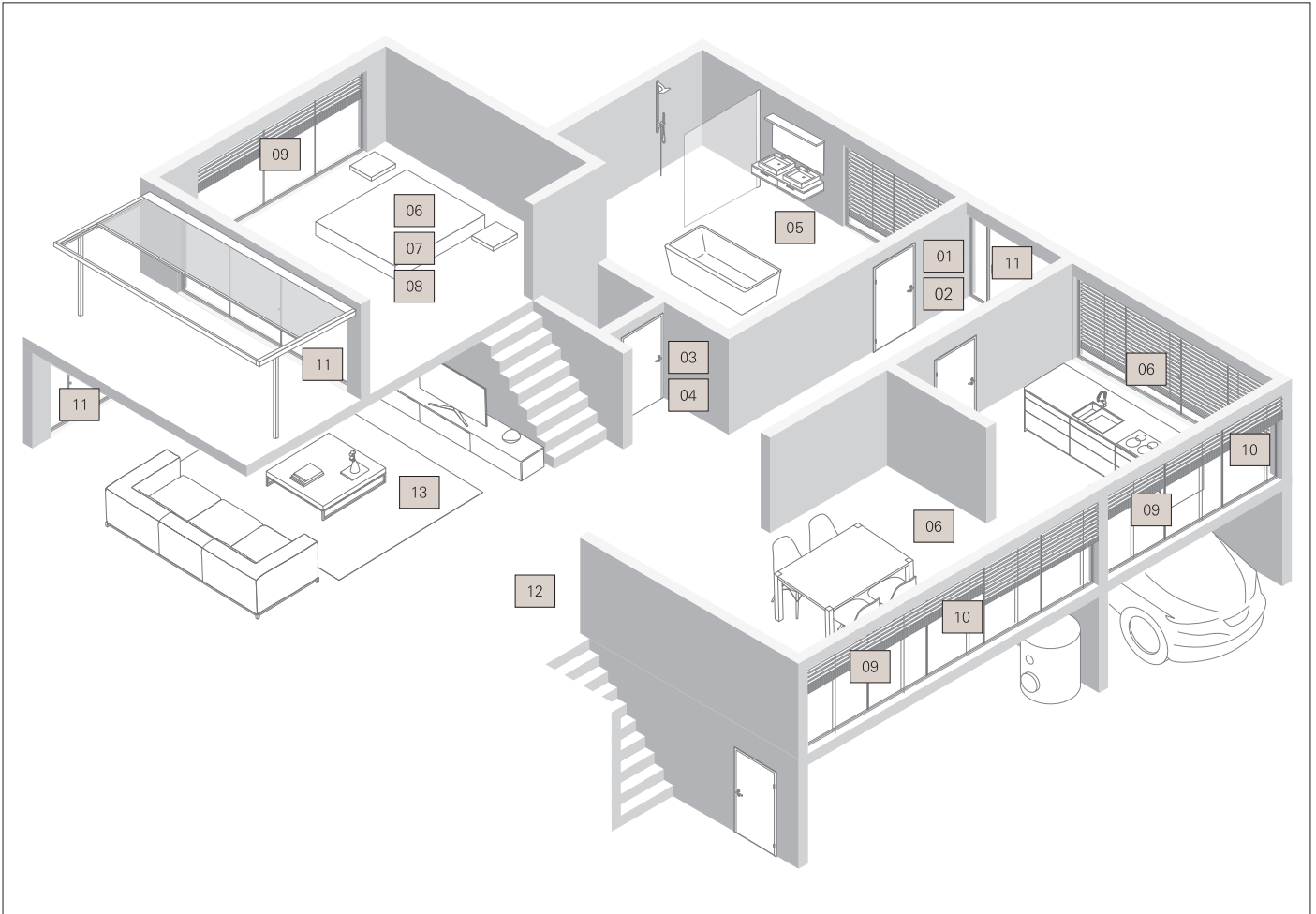

01	Hands-free lighting	08	New operating points
02	Alarm function	09	Shading using group control
03	Automatic lighting for the guest WC	10	Automatic shading in bright sunlight
04	Lighting and fan for the guest WC	11	Lock-out protection
05	Lighting, fan and radio for the bathroom	12	Presence simulation
06	Convenient lighting control	13	Scene for a cosy TV evening
07	Dimming both spotlights with auxiliary unit		

2.1.1 Hands-free lighting

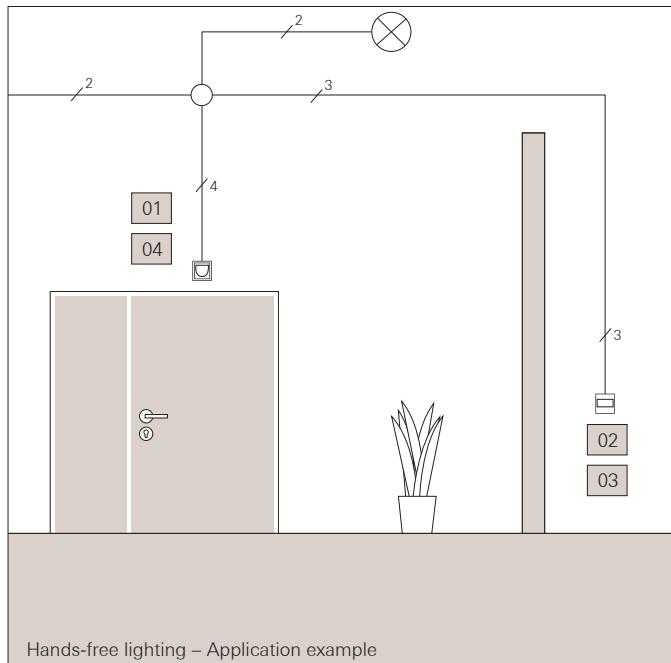

Have the hallway light switch on automatically when you come home in the dark. With a Gira motion detector or presence and motion detector, you can set up this function in no time at all. For long or winding hallways, simply extend the detection field with a 3-wire auxiliary insert and an additional motion detector. When no-one is in the detection range, the lighting automatically switches off again. Of course, the Gira motion detectors also take into account ambient brightness. If there is enough daylight, the light stays off. It's as simple as that.

Number	Components	Quantity	Order no.
01	Relay switching insert	1	5403 00
02	3-wire auxiliary insert	1	5409 00
03	Motion detector top unit 1.10 m Standard	1	5373 ..
04	Motion detector top unit 2.20 m Standard	1	5375 ..

Note:

If a 3-wire auxiliary insert is used, no operating top unit may be used on the main unit.

Number of 3-wire auxiliary inserts: ten (max.)
 Total cable length: 100 metres (max.)

2.1.2 Alarm function

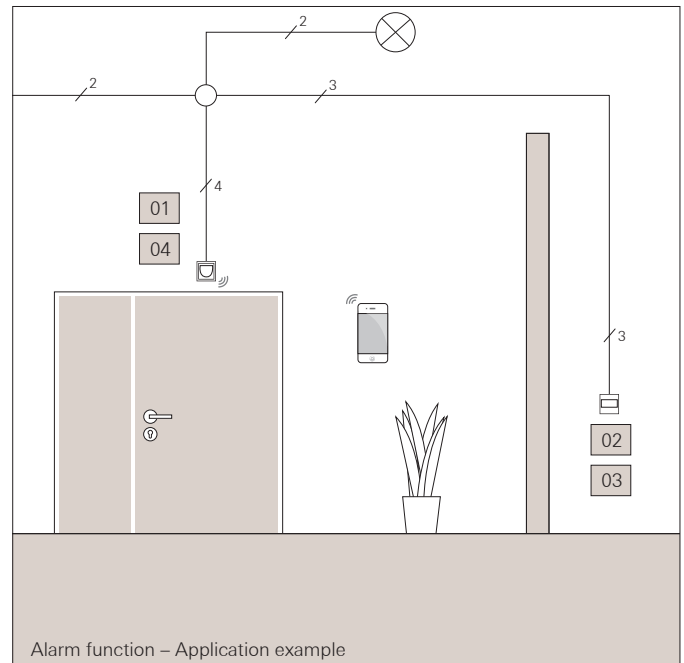

With one click in the Gira System 3000 App, the motion detector becomes your watchdog.

The activated alarm function detects movement by people and makes the lighting flash. Burglars are unsettled and deterred. The light signal may also alert neighbours. The alarm function is triggered independently of brightness and can be used together with other additional functions such as presence simulation. Of course, you can extend the detection field here too with up to ten auxiliary units.

Number	Components	Quantity	Order no.
01	Relay switching insert	1	5403 00
02	3-wire auxiliary insert	1	5409 00
03	Motion detector top unit 1.10 m Standard	1	5373 ..
04	Motion detector top unit 2.20 m Komfort BT	1	5376 ..

Note:

If a 3-wire auxiliary insert is used, no operating top unit may be used on the main unit.

Number of 3-wire auxiliary inserts: ten (max.)
 Total cable length: 100 metres (max.)

2.1.3 Automatic lighting for the guest WC

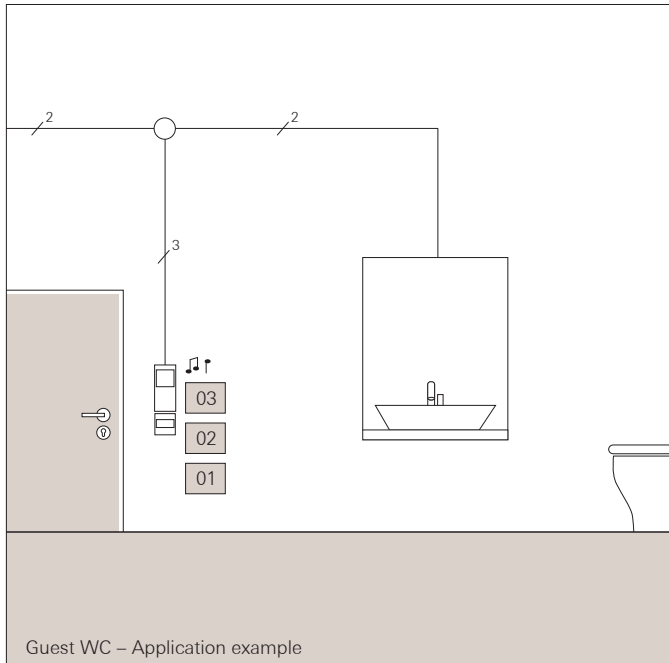

In windowless rooms such as cellars, attics and garages, a motion detector is very useful. And automatic lighting in the windowless guest WC also saves guests from searching for the light switch. That's not enough? How would it be if the radio played music as well? No problem with the Gira RDS flush-mounted radio! When no more movement is detected, the motion detector automatically switches off the lighting and the radio.

Number	Components	Quantity	Order no.
01	Relay switching insert	1	5403 00
02	Motion detector top unit 1.10 m Standard	1	5373 ..
03	Gira RDS flush-mounted radio	1	2280 ..

2.1.4 Lighting and fan for the guest WC

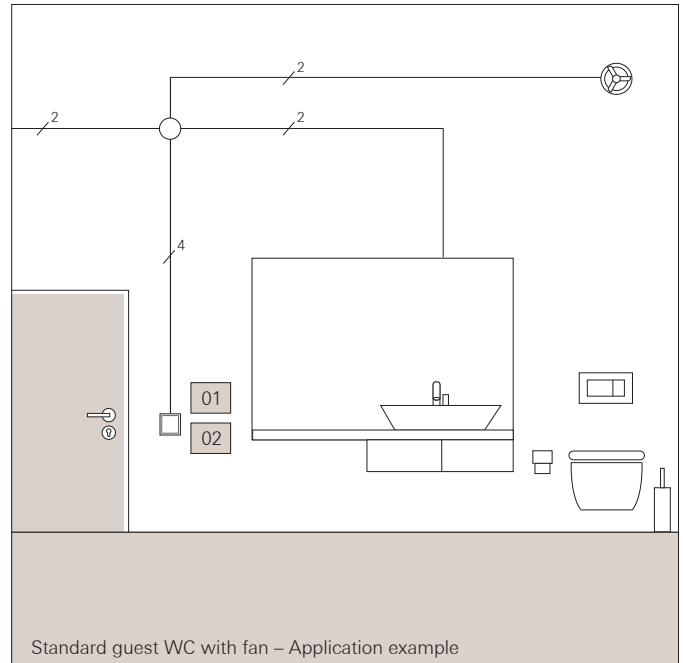

There are often no windows in guest toilets, but a fan is usually installed to ensure the necessary air exchange. At the touch of a button, you can conveniently switch on the light and fan (also with a time delay). When you leave the room and switch off the light, the fan can continue to run for some time.

Number	Components	Quantity	Order no.
01	Relay switching insert, 2-gang	1	5404 00
02	Operating top unit	1	5360 ..

2.1.5 Lighting, fan and radio for the bathroom

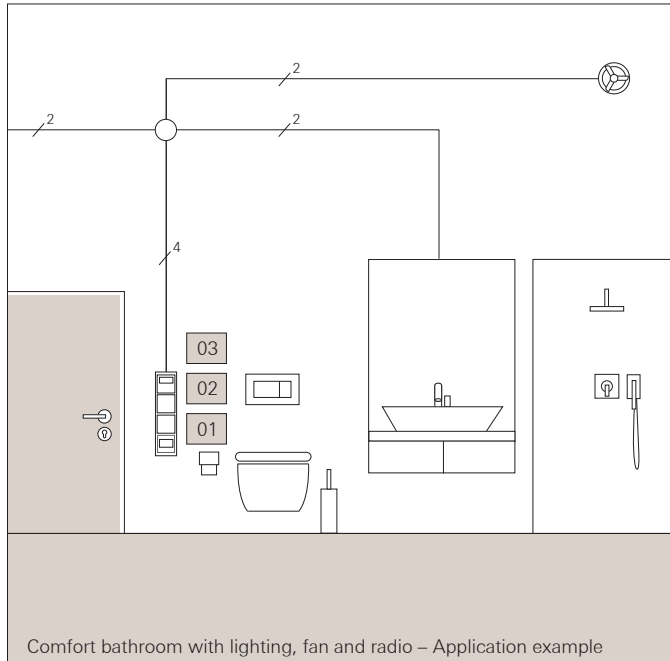

Would you like to automatically switch on the light, fan and Gira RDS flush-mounted radio when you enter your bathroom? No problem! You can also decide whether you want the fan to switch on immediately or with a time delay. When no more movement is detected, the motion detector automatically switches off the lighting and the radio. The fan may continue to run for a set time if you wish.

Number	Components	Quantity	Order no.
01	Relay switching insert, 2-gang	1	5404 00
02	Motion detector top unit 1.10 m Standard	1	5373 ..
03	Gira RDS flush-mounted radio	1	2280 ..

Note:
 To activate or deactivate a switch-on delay of 3 minutes for the second relay output, you will need a System 3000 operating top unit, order no. 5360 .. .
 When delivered, the switch-on delay and delay time are deactivated.

2.1.6 Convenient lighting control with an auxiliary unit

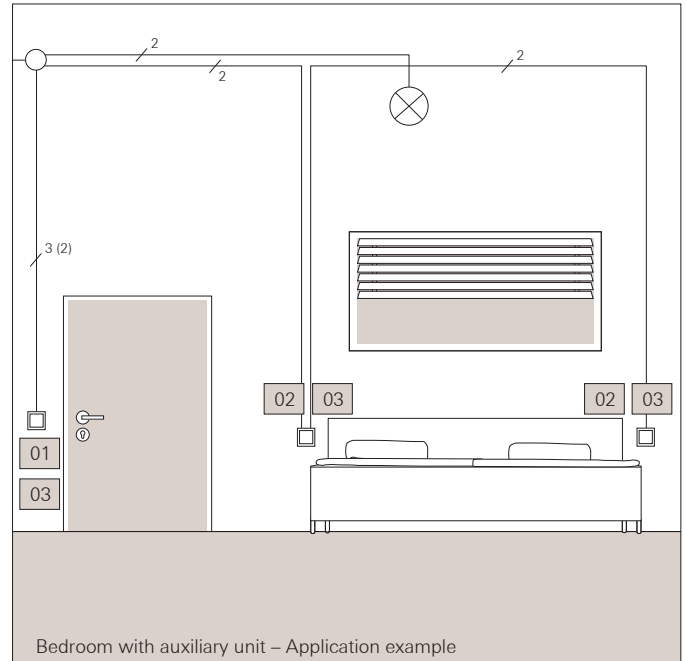

Getting up again to switch off the main bedroom lighting? With the 2-wire auxiliary insert, you can add additional operating points to the main unit. The range of functions is specified by the main unit. Looking for even more convenience? The bedroom lighting is dimmable with the universal LED dimming insert Komfort as the main unit. Even via auxiliary units.

Number	Components	Quantity	Order no.
01	Universal LED dimming insert Komfort	1	5401 00
02	2-wire auxiliary insert	2	5408 00
03	Operating top unit	3	5360 ..

2.1.7 Dimming both spotlights with an auxiliary unit

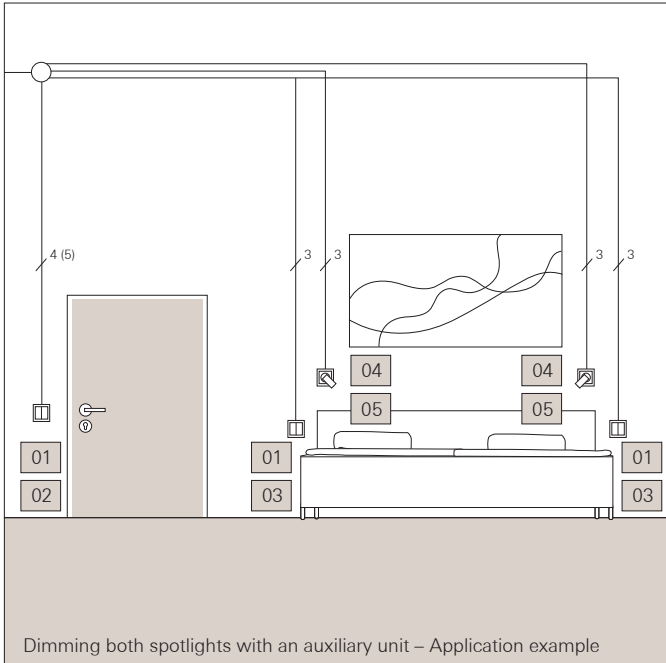

Control two lights with one dimmer and operate them from several points. This is very easy with the Gira universal LED dimming insert Komfort, 2-gang and the 3-wire auxiliary insert. You can switch on and dim each light separately from each operating point.

The following table shows you which of the Gira System 3000 top units and inserts you can combine with each other.

Number	Components	Quantity	Order no.
01	Operating top unit, 2-gang	3	5362 ..
02	Universal LED dimming insert Komfort, 2-gang	1	5402 00
03	3-wire auxiliary insert	2	5409 00
04	Plug & Light light socket outlet	2	2688 ..
05	Plug & Light spotlight, dimmable	2	2692 ..

2.1.8 New operating points

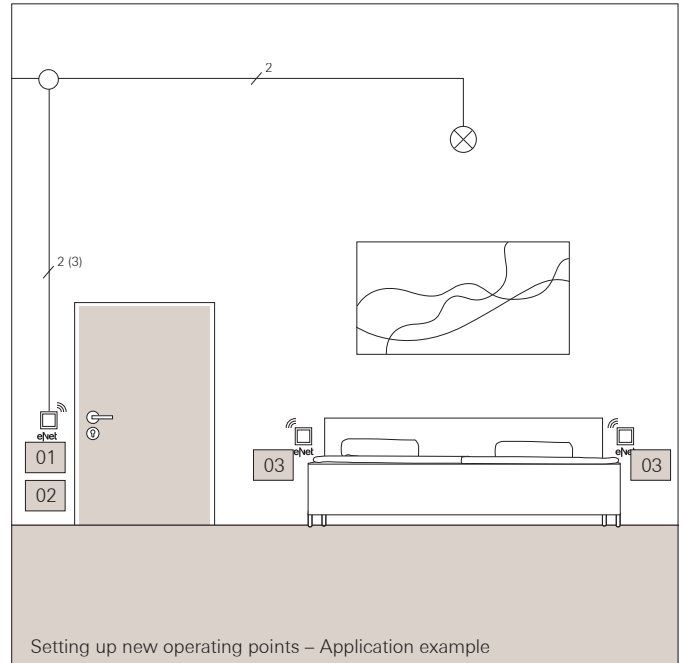

Would you rather not get up to switch off the main lighting in the bedroom? But you don't have an auxiliary line available and don't want to install a new line? Then simply equip your dimming insert with an eNet wireless operating top unit. You can now integrate additional operating points using the eNet wireless system, e.g. with the battery-operated eNet wireless wall transmitters.

Number	Components	Quantity	Order no.
01	System 3000 Universal LED dimming insert Standard	1	5400 00
02	eNet wireless operating top unit	1	5495 00
03	eNet wireless wall transmitter, 1-gang	2	5331 100

2.1.9 Shading entire areas using group control

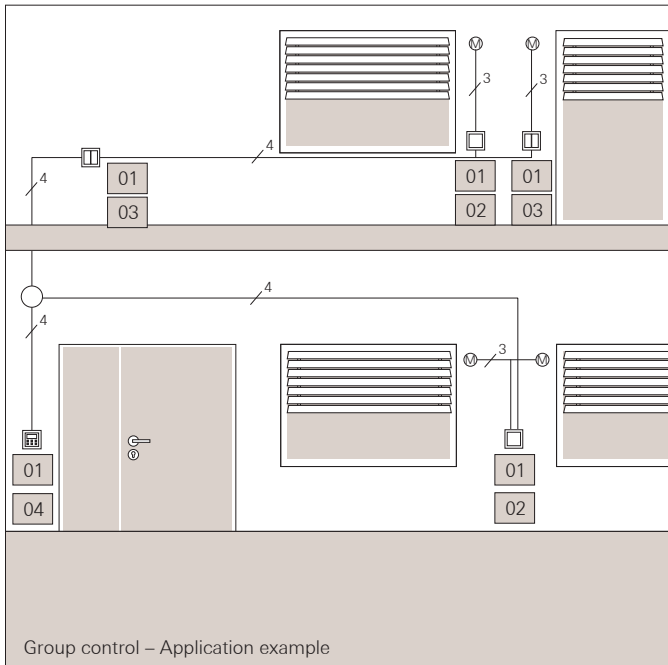

With the blind control insert with auxiliary input, you can cascade shading so that the blinds can be flexibly controlled, per room, per floor or per building – individually and conveniently. A blind control insert with auxiliary input controls one or more shading motors¹⁾; another blind control insert with auxiliary input in turn combines several blind control inserts into one group. With the blind timer and timer display as a group control, you can control the entire shading system automatically as you wish. Individually programmed or, thanks to the astro function, in sync with sunrise and sunset. The timer program can also take care of raising and lowering the blinds when you're on holiday. The automatic lowering (blocking function) of the shutters can be disabled with the aid of an operating top unit Memory. In addition, a memory function allows two additional movement times for the connected motors.

Number	Components	Quantity	Order no.
01	Blind control insert with auxiliary input	5	5414 00
02	Operating top unit arrow symbols	2	5361 00
03	Operating top unit Memory arrow symbols	2	5363 ..
04	Blind timer and timer Display	1	5366 ..

¹⁾ Please note the maximum connectible motor power of 700 W, even when controlling several motors via a blind control insert. If you connect several motors in parallel, the motors must be suitable for this. Alternatively, you can use cut-off relays.

2.1.10 Automatic shading in bright sunlight

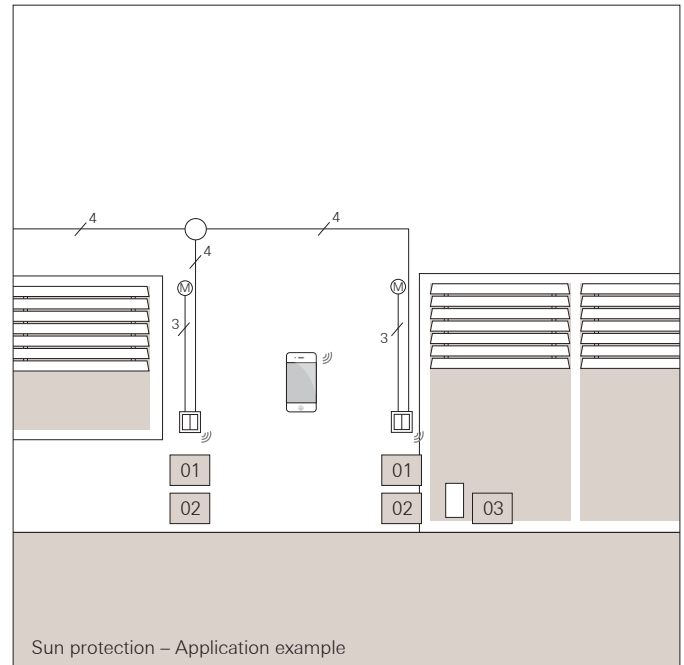

With the Gira blind timers and timers BT, you can conveniently shade your living area with time control. Thanks to the astro function, no-one has to worry about programming or switching to summer or winter time. If you also install a brightness and temperature sensor BT, your automated shading is complete. The brightness and temperature sensors BT monitor the south and west facing windows. If a certain brightness is exceeded, the shading goes down to protect the room from overheating and from strong UV radiation. The brightness threshold, shading position and time schedule can be set individually via the Gira System 3000 App. With the water-protected surface-mounted housing for the brightness and temperature sensor BT, the sensor can be mounted outdoors. Please keep the wireless range of the sensor in mind!

Number	Components	Quantity	Order no.
01	Blind control insert with auxiliary input	2	5414 00
02	Blind timer and timer BT	2	5367 ..
03	Brightness and temperature sensor BT	1	5466 02
04	Housing for brightness and temperature sensor	1	5467 00

2.1.11 Lock-out protection

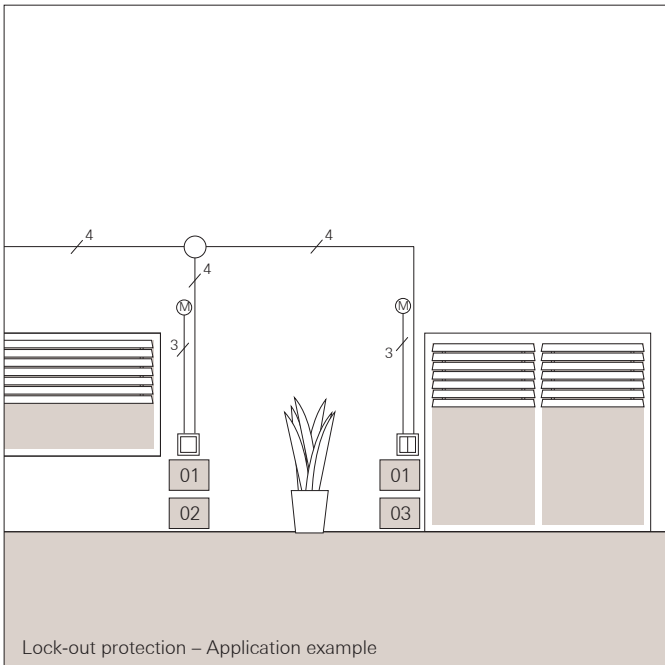

Have you thought of everything? Can the shading be controlled individually? Does it automatically provide shade in strong sunlight and track the astro function every day? We think we can take it even one step further for you. With our practical blocking function, you can prevent the shutters from closing automatically if someone else is still outdoors. You can activate the blocking function simply by pressing a button on the operating top unit Memory.

Number	Components	Quantity	Order no.
01	Blind control insert with auxiliary input	2	5414 00
02	Operating top unit arrow symbols	1	5361 ..
03	Operating top unit Memory arrow symbols	1	5363 ..

2.1.12 Presence simulation

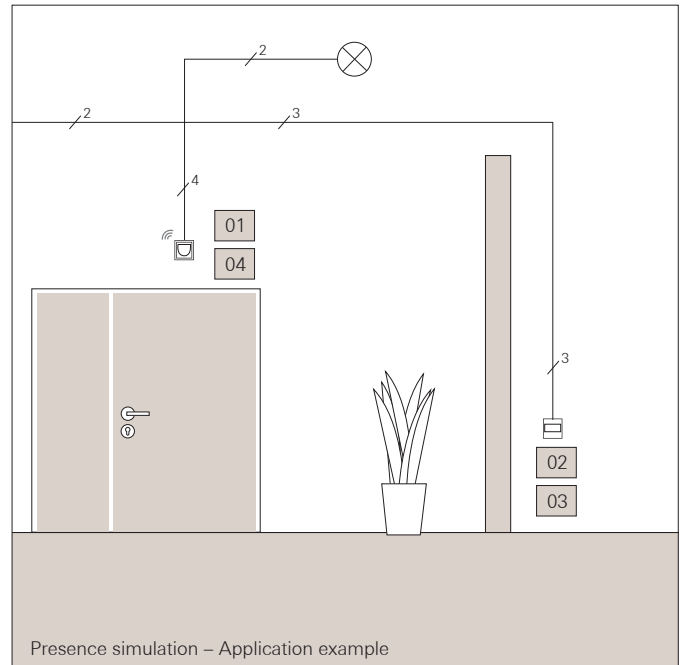

With Gira's presence simulation feature, homes and apartments appear occupied even when the occupants are away. In normal operation, the individual switching times of the last 24 hours are permanently saved in the motion detector top unit. If more than 60 switching operations are carried out, the oldest ones are overwritten. If presence simulation has been activated using the Gira System 3000 App, the lights are switched on at the times saved the previous day, depending on brightness. They are switched off as usual after the delay time has elapsed. If movement is detected, the light is also switched on or the delay time is extended. The shading control system is also easy to automate using the Gira System 3000 App, so that no-one has to look after your home or apartment while you're on holiday.

Number	Components	Quantity	Order no.
01	Relay switching insert	1	5403 00
02	3-wire auxiliary insert	1	5409 00
03	Motion detector top unit 1.10 m Standard	1	5373 ..
04	Motion detector top unit 2.20 m Komfort BT	1	5376 ..

Note:

If a 3-wire auxiliary insert is used, no operating top unit may be used on the main unit.

Number of 3-wire auxiliary inserts: ten (max.)
 Total cable length: 100 metres (max.)

2.1.13 Scene for a cosy TV evening

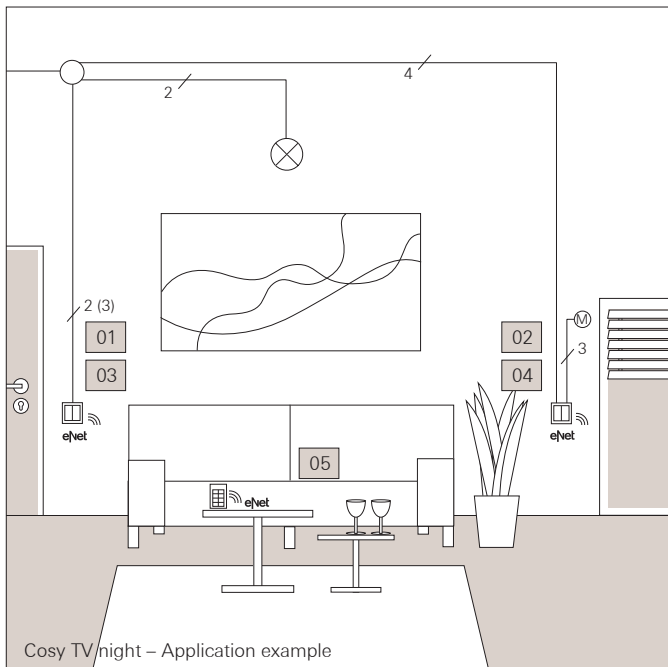

Get the perfect atmosphere for a cosy evening in front of the TV at the touch of a button. Mount one eNet wireless operating top unit each on the blind control insert and the dimming insert. Connect the two eNet wireless operating top units to an eNet wireless hand-held transmitter to create a TV scene.

The TV scene is activated when you operate the eNet wireless hand-held transmitter, which not only switches on the light to a certain brightness level, but also lowers the shutters.

Number	Components	Quantity	Order no.
01	Universal LED dimming insert Standard	1	5400 00
02	Blind control insert without auxiliary input	1	5415 00
03	eNet wireless operating top unit arrow symbols	1	5494 ..
04	eNet wireless operating top unit Memory arrow symbols	1	5492 ..
05	eNet wireless hand-held transmitter, 4-gang	1	5354 10

2.2 Commercial properties

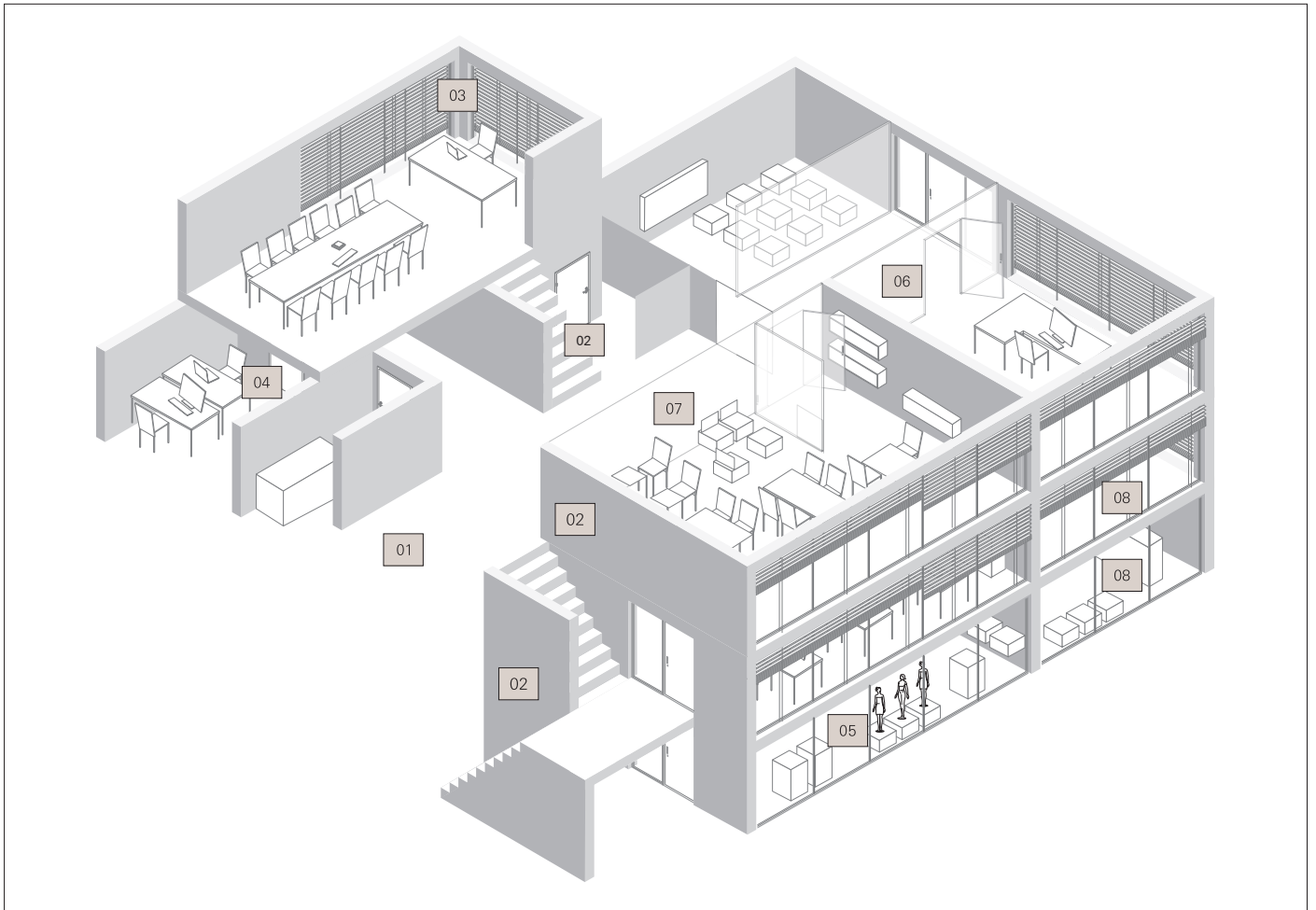

- | | |
|----|--|
| 01 | Lighting control in the entrance area |
| 02 | Automatic staircase lighting |
| 03 | Lighting and shading in the conference room |
| 04 | Presence detector with constant light function |
| 05 | Display window |
| 06 | Semi-automatic light with energy-saving function |
| 07 | Switching restaurant lights centrally |
| 08 | Hotel corridor |

2.2.1 Daylight-dependent lighting control in the entrance area

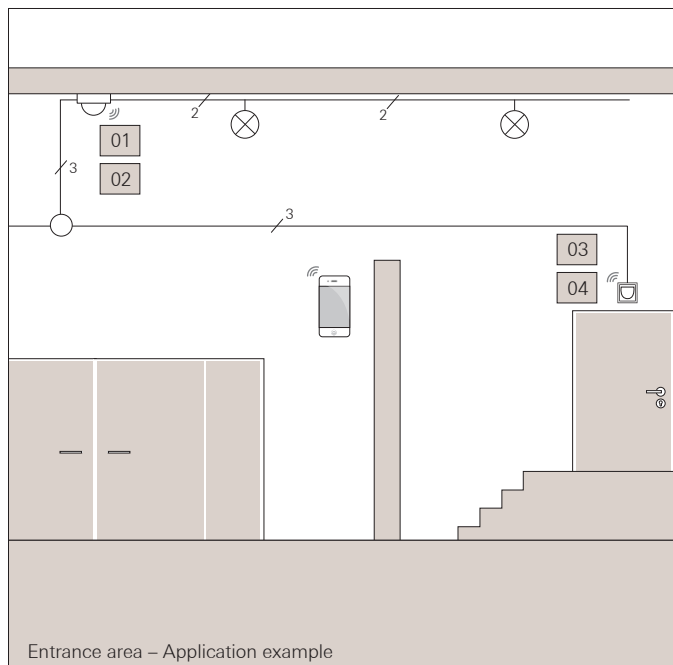

The entrance area of office buildings is usually heavily frequented before and after work. With the Gira System 3000, you can adjust the lighting control by combining different functions and time programs using the Gira System 3000 App: At the start of the work day, the lighting switches permanently on between 8 am and 10 am with a brightness of 80%. Between 10 am and 4 pm, the lighting provides a basic brightness of 20% and increases to 80% when motion is detected. From 4 pm to 6 pm, the lighting switches permanently on again with a brightness of 80%. After 6 pm, the basic brightness is switched off and the lighting is switched on only when motion is detected. At the weekend, the basic brightness is also switched off, and the lighting reacts exclusively to motion.

Number	Components	Quantity	Order no.
01	Universal LED dimming insert Komfort	1	5401 00
02	Presence and motion detector 360° top unit BT	1	5377 02
03	3-wire auxiliary insert	1	5409 00
04	Motion detector top unit 2.20 m Komfort BT	1	5376 ..

2.2.2 Automatic staircase lighting

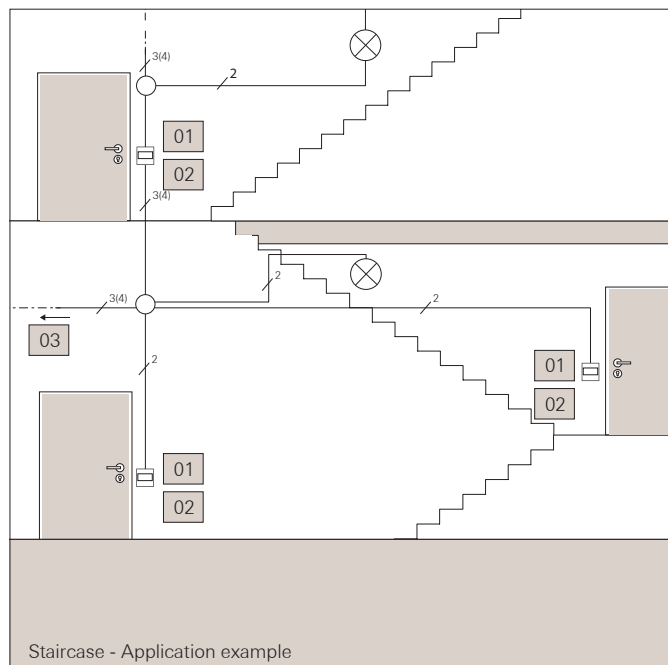

With the Gira System 3000, you can make staircases safer and more convenient without having to lay new cables. With the combination of impulse insert, motion detector top unit and staircase timer, you can simply use the existing cable structure (3- or 4-conductor system). This saves installation costs during implementation and energy costs during operation. If desired, illuminated or not-illuminated buttons can also be installed in combination with the motion detectors.

Number	Components	Quantity	Order no.
01	Impulse insert	3	5410 00
02	Motion detector top unit 1.10 m Standard	3	5373 ..
03	Staircase light timer	1	0821 00

2.2.3 Lighting and shading as required in the conference room

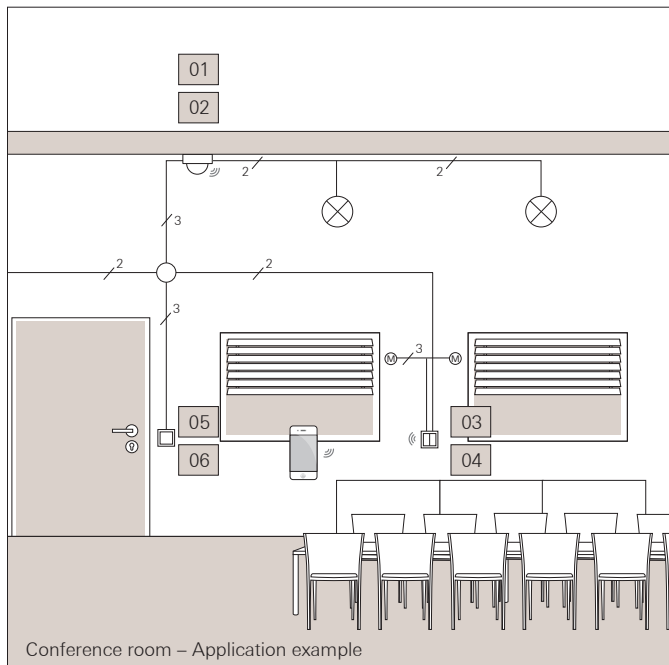

Never again too bright during a presentation, never again too dark during a meeting. With the combination of lighting and shading control, you can conveniently use the app to adjust lighting conditions to current requirements at the touch of a button. If lighting is not required during a presentation, it is switched off for the entire room using an auxiliary unit or smartphone. If there is too much daylight, the windows can be shaded according to the same principle. For lighting during a meeting, the available daylight is measured. Based on this, the lighting intensity adjusts to the actual lighting requirements. When the meeting is over, the complete lighting is switched off after a pre-set delay.

Number	Components	Quantity	Order no.
01	Universal LED dimming insert Komfort	1	5401 00
02	Presence and motion detector 360° top unit BT	1	5377 02
03	Blind control insert without auxiliary input	1	5415 00
04	Blind timer and timer BT	1	5367 ..
05	2-wire auxiliary insert	1	5408 00
06	Operating top unit	1	5360 ..

2.2.4 Individual presence detectors with constant light function

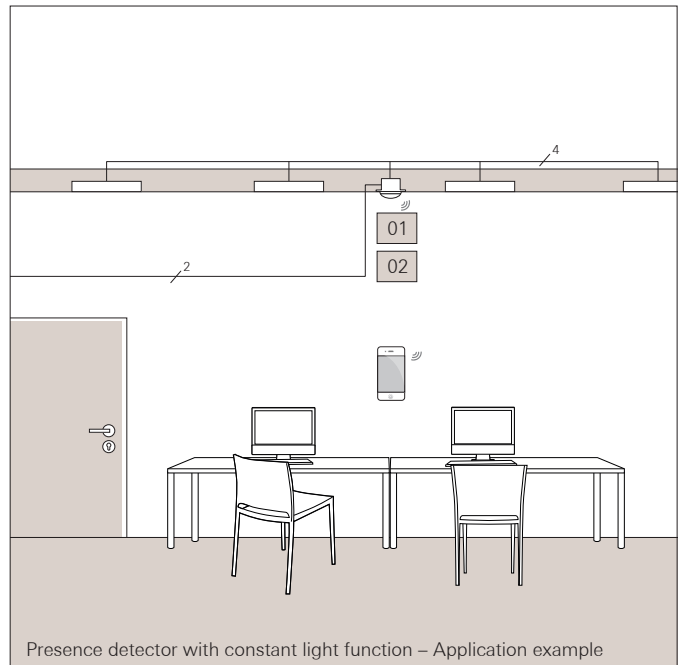

By combining Gira presence detectors with a DALI Power control unit, you can meet the different lighting requirements in open-plan offices. The presence detectors detect even the slightest movement, measure the current brightness at that precise location, and switch on as much light as is needed using constant light control. If an office is not occupied, the lighting is also switched off. The desired brightness and other settings can be individually adjusted using the Gira System 3000 App. Conveniently via Bluetooth, without having to get a ladder out. At a later date, too. And with no need for a network connection.

Number	Components	Quantity	Order no.
01	DALI Power control unit, flush-mounted insert	1	5406 00
02	Presence and motion detector 360° top unit BT	1	5377 02

2.2.5 Semi-automatic light with energy-saving function

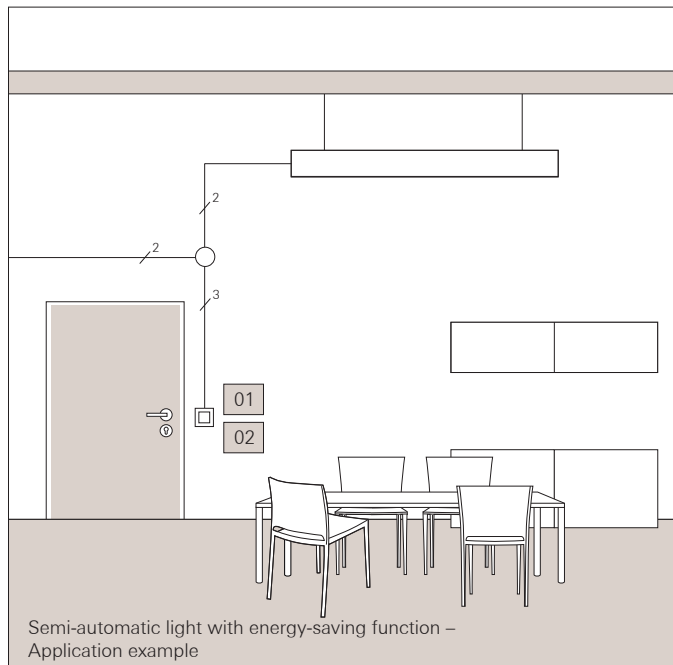

There are rooms in which the light is always on, although no-one is present. Solve this problem with the simplest switching insert from System 3000. The relay switching insert has an integrated and adjustable delay time, after which the light is automatically switched off as desired. The function is particularly suitable for rooms where no-one usually stays for a long time, such as office kitchens, server rooms, WCs and copier rooms. The lighting is switched on with using an operating top unit and switches off automatically after one, five, 30 or 60 minutes. The functions can be conveniently adjusted using a button. Of course, the light can also be switched off manually at any time.

Number	Components	Quantity	Order no.
01	Relay switching insert	1	5403 00
02	Operating top unit	1	5360 ..

2.2.6 Display window

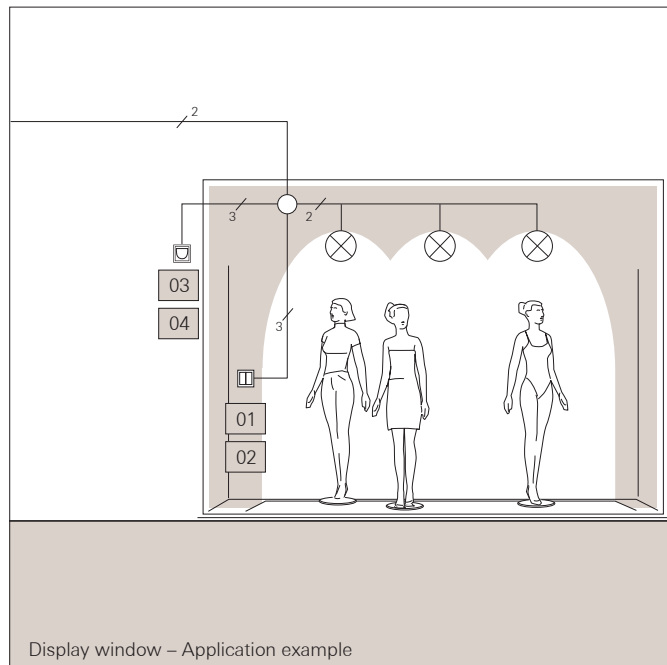

Would you like to efficiently illuminate your windows in the dark using time control? With the Memory function on the operating top unit Memory, you can set the lighting in your display window to stay on continuously between 5 pm and midnight. As manual actuation always has priority over automatic operation, you can of course switch the lighting on or off manually at any time using the left rocker. The lighting is then controlled depending on the movement detected by the motion detector. With the blocking function of the operating top unit Memory, you can deactivate both the motion detector and the Memory function and thereby control the lighting in your display window completely manually.

Number	Components	Quantity	Order no.
01	Relay switching insert	1	5403 00
02	Operating top unit Memory arrow symbols	1	5363 ..
03	3-wire auxiliary insert	1	5409 00
04	Motion detector top unit 2.20 m Standard	1	5375 ..

2.2.7 Switching restaurant lights centrally

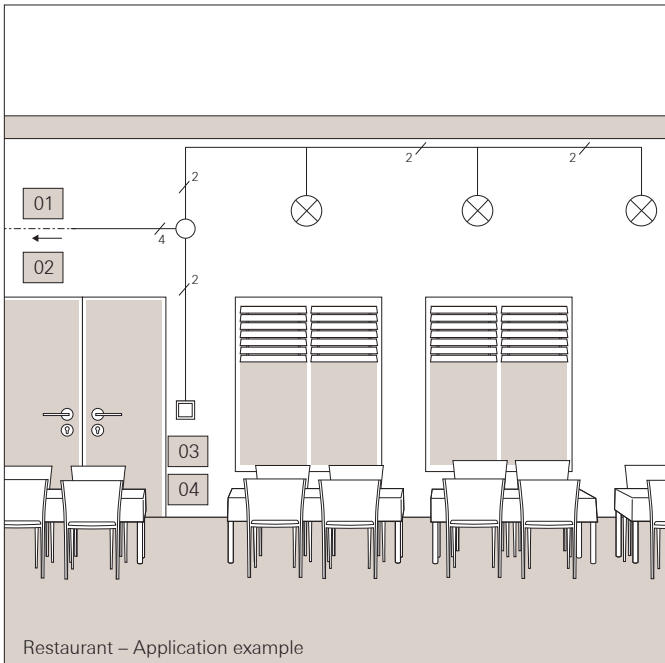

As a restaurant or pub operator, do you want to be able to switch your light from one central spot without having to constantly operate several switches in different rooms? With the universal LED dimmer DRA, you can switch and dim the entire lighting system using the operating top unit on the 2-wire auxiliary insert. The universal LED power boosters enable up to 600 W of LED lighting to be connected. The uniform brightness of the entire lighting system ensures a harmonious feel-good atmosphere.

2.2.8 Hotel corridor – Check in and feel welcome

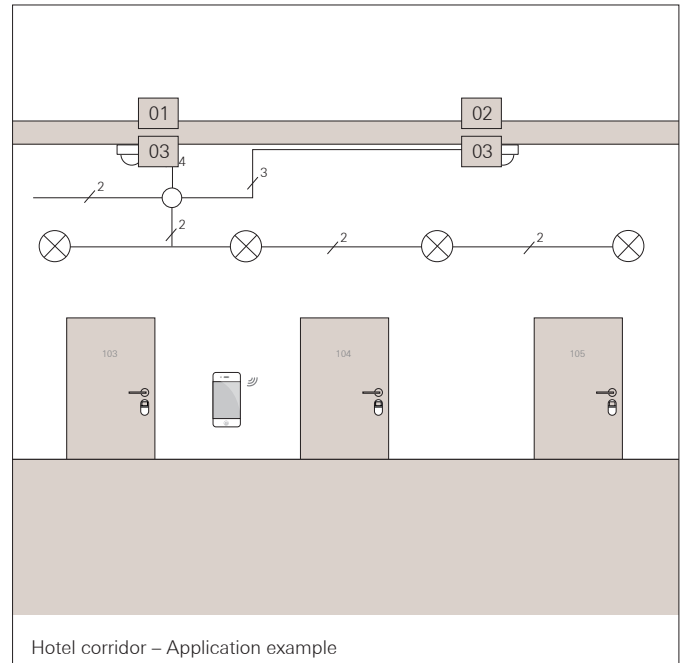







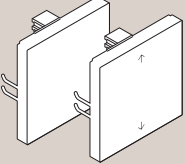
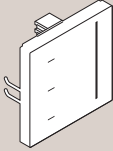
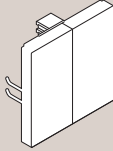
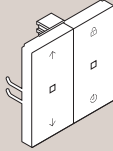

Basic lighting is required in hotel corridors. The presence and motion detector with 360° top unit BT in combination with dimmers from the Gira System 3000 offers this function and more: when a guest enters the detection field, the lighting in the hotel corridor switches from the preselected basic brightness (40%) to the switch-on brightness (100%), and the guest can walk to their hotel room in plenty of light. The settings for the detection field of the BT presence and motion detector 360° top unit as well as the delay time and switch-on brightness can be conveniently adjusted using the Gira System 3000 App. Once you have set the perfect parameters for a device, you can copy the settings and transfer them to all the other devices in the hotel.

Number	Components	Quantity	Order no.
01	Universal LED dimmer DRA	1	2365 00
02	Universal LED power booster DRA	1	2383 00
03	Operating top unit	1	5360 ..
04	2-wire auxiliary insert	1	5408 00

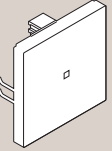
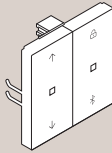
Number	Components	Quantity	Order no.
01	Universal LED dimming insert Komfort	1	5401 00
02	3-wire auxiliary insert	1	5409 00
03	Presence and motion detector 360° top unit BT	2	5377 02

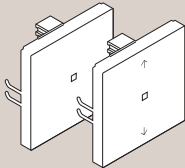
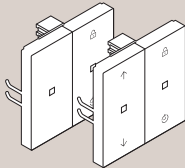
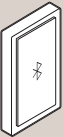
3 // Device overview

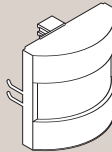
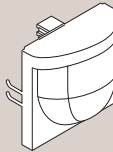
In line with the modular principle, the Gira System 3000 provides different combinable top units and inserts for the individual control of lighting and shading.

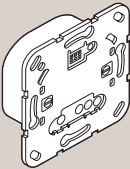
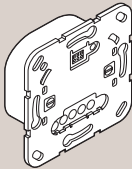
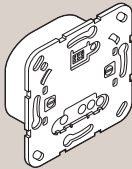
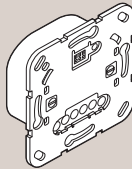
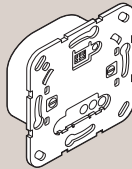
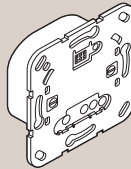
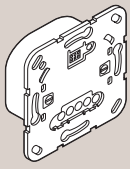
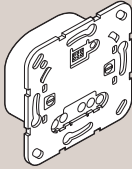
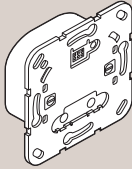
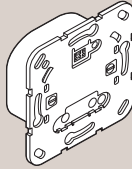
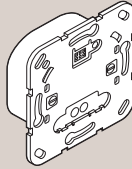
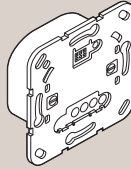
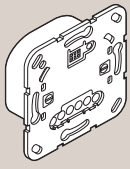
						
	Gira System 3000 operating top unit and operating top unit arrow symbols	Gira System 3000 touch top unit	Gira System 3000 operating top unit, 2-gang	Gira System 3000 operating top unit Memory arrow symbols	Gira System 3000 blind timer and timer Display	Gira System 3000 operating top unit BT
Top units						
	Gira System 3000 blind timer and timer BT	Gira System 3000 room temperature controller Display	Gira System 3000 room temperature controller BT	eNet wireless operating top unit arrow symbols/operating top unit	eNet wireless operating top unit Memory arrow symbols/Memory	Gira System 3000 brightness and temperature sensor BT
						
Gira System 3000 motion detector top unit 1.10 m Standard	Gira System 3000 motion detector top unit 1.10 m Komfort BT	Gira System 3000 motion detector top unit 2.20 m Standard	Gira System 3000 motion detector top unit 2.20 m Komfort BT	Gira System 3000 presence and motion detector 360° top unit BT		
Inserts						
	Gira System 3000 relay switching insert	Gira System 3000 relay switching insert, 2-gang	Gira System 3000 electronic switching insert	Gira System 3000 room temperature controller insert with sensor connection	Gira System 3000 universal LED dimming insert Standard	Gira System 3000 universal LED dimming insert Komfort
						
	Gira System 3000 universal LED dimming insert Komfort, 2-gang	Gira System 3000 DALI Power control unit flush-mounted insert	Gira System 3000 2-wire auxiliary insert	Gira System 3000 3-wire auxiliary insert	Gira System 3000 impulse insert	Gira System 3000 blind control insert without auxiliary input
						
Gira System 3000 blind control insert with auxiliary input						















3.1 Top units and inserts

Top units	Lighting	Shading	Heating	Order no.
System 3000 operating top unit	✓	✓		5360 ..
System 3000 operating top unit arrow symbols	✓	✓		5361 ..
System 3000 touch top unit	✓	✓		5365 ..
System 3000 operating top unit, 2-gang	✓			5362 ..
System 3000 operating top unit Memory arrow symbols	✓	✓		5363 ..
System 3000 blind timer and timer Display	✓	✓		5366 ..
System 3000 operating top unit BT	✓	✓		5368 ..
System 3000 blind timer and timer BT	✓	✓		5367 ..
eNet wireless operating top unit arrow symbols	✓	✓		5494 ..
eNet wireless operating top unit	✓	✓		5495 ..
eNet wireless operating top unit Memory arrow symbols	✓	✓		5492 ..
eNet wireless operating top unit Memory	✓	✓		5493 ..
System 3000 room temperature controller Display			✓	5393 ..
System 3000 room temperature controller BT			✓	5394 ..
System 3000 motion detector top unit 1.10 m Standard	✓			5373 ..
System 3000 motion detector top unit 1.10 m Komfort BT	✓			5374 ..
System 3000 motion detector top unit 2.20 m Standard	✓			5375 ..
System 3000 motion detector top unit 2.20 m Komfort BT	✓			5376 ..
System 3000 presence and motion detector 360° top unit BT	✓			5377 02

Inserts	Lighting	Shading	Heating	Order no.
System 3000 relay switching insert	✓		✓	5403 00
System 3000 relay switching insert, 2-gang	✓			5404 00
System 3000 electronic switching insert	✓		✓	5405 00
System 3000 room temperature controller insert with sensor connection			✓	5395 00
System 3000 universal LED dimming insert Standard	✓			5400 00
System 3000 universal LED dimming insert Komfort	✓			5401 00
System 3000 universal LED dimming insert Komfort, 2-gang	✓			5402 00
System 3000 DALI Power control unit, flush-mounted insert	✓			5406 00
System 3000 2-wire auxiliary insert	✓			5408 00
System 3000 3-wire auxiliary insert	✓			5409 00
System 3000 impulse insert	✓			5410 00
System 3000 blind control insert without auxiliary input		✓		5415 00
System 3000 blind control insert with auxiliary input		✓		5414 00

Sensors	Lighting	Shading	Heating	Order no.
System 3000 brightness and temperature sensor BT	✓	✓	✓	5403 00

3.2 Combination options for lighting and blind control

<p>The table shows you which Gira System 3000 top units and inserts you can combine with each other.</p>			Inserts				
			Lighting control				
							
			5403 00	5404 00	5405 00	5400 00	5401 00
Top units		Operating top unit and operating top unit arrow symbols 5360 .. 5361 ..	switching	switching a1 + a2, switch-on delay a2, delay time a2	switching	switching dimming	switching dimming
		Touch top unit 5365 ..	switching	switching a1 + a2, switch-on delay a2, delay time a2	switching	switching dimming sliding	switching dimming sliding
		Operating top unit, 2-gang 5362 ..	switching (left rocker only)	switching a1 + a2 separate	switching (left rocker only)	switching dimming (left rocker only)	switching dimming (left rocker only)
		Operating top unit Memory arrow symbols 5363 ..	switching Memory	switching a1 + a2 switch-on delay a2, delay time a2	switching Memory	switching dimming Memory	switching dimming Memory
		Blind timer and timer Display 5366 ..	switching Memory Timer	switching a1 + a2 switch-on delay a2, delay time a2	switching Memory timer	switching dimming Memory timer	switching dimming Memory timer
		Operating top unit BT 5368 ..	switching timer app operation	switching a1 + a2 switch-on delay a2, delay time a2	switching timer app operation	switching dimming timer app operation	switching dimming timer app operation
		Blind timer and timer BT 5367 ..	switching timer app operation	switching a1 + a2 switch-on delay a2, delay time a2	switching timer app operation	switching dimming timer app operation	switching dimming timer app operation
		eNet wireless operating top unit and eNet wireless operating top unit arrow symbols 5495 .. 5194 ..	switching eNet	switching a1 + a2 switch-on delay a2, delay time a2, eNet	switching eNet	switching dimming eNet	switching dimming eNet
		eNet wireless operating top unit Memory and eNet wireless operating top unit Memory arrow symbols 5493 .. 5492 ..	switching Memory eNet	switching a1 + a2 switch-on delay a2, delay time a2, eNet	switching Memory eNet	switching dimming Memory eNet	switching dimming Memory eNet









 For mounting heights of up to 1.10 metres with an exclusively horizontally aligned detection range, and therefore no separate range limitation outdoors.

 For mounting heights of up to 2.20 metres with an angled, vertically aligned detection range.



















 Setting and operation with Gira System 3000 App.

 Depends on the main unit to be controlled.

Inserts

Lighting control					Blind control		Heating control
							
Universal LED dimming insert Komfort, 2-gang	DALI Power control unit flush-mounted insert	2-wire auxiliary insert	3-wire auxiliary insert	Impulse insert with staircase-light automatic control switch	Blind control insert with auxiliary input	Blind control insert without auxiliary input	Room temperature controller insert with sensor connection
5402 00	5406 00	5408 00	5409 00	5410 00 0821 00	5414 00	5415 00	5395 00
switching dimming a1 + a2 together	switching dimming Tunable White	① switching dimming Tunable White	① switching dimming Tunable White	switching on	Up/down individual position	Up/down individual position	---
switching dimming a1 + a2 together sliding	switching dimming sliding	---	① switching dimming sliding	---	Up/down individual position	Up/down sliding, individual position	---
switching dimming a1, a2 separate	switching dimming Tunable White	---	① switching dimming	---	Up/down individual position (left rocker only)	Up/down individual position (left rocker only)	---
switching dimming a1 + a2 together Memory	switching dimming Memory	---	① switching dimming	---	Up/down individual position Memory	Up/down individual position Memory	---
switching, dimming a1 + a2 together Memory timer	switching dimming Memory timer	---	① switching dimming	---	Up/down, position Memory blind timer	Up/down, position Memory blind timer	---
switching, dimming a1 a2 together timer app operation	switching dimming timer app operation	---	① switching dimming	---	Up/down, position blind timer app operation	Up/down, position blind timer app operation	---
switching, dimming a1 a2 together timer app operation	switching dimming timer app operation	---	① switching dimming	---	Up/down, position blind timer app operation	Up/down, position blind timer app operation	---
switching dimming a1 + a2 together eNet	switching dimming eNet	---	① switching dimming	---	Up/down individual position eNet	Up/down individual position eNet	---
switching dimming a1 + a2 together Memory, eNet	switching dimming Memory eNet	---	① switching dimming eNet	---	Up/down individual position eNet Memory	Up/down individual position eNet Memory	---

3.3 Combination options for lighting, blind and heating control

<p>The table shows you which Gira System 3000 top units and inserts you can combine with each other.</p>			Inserts				
			Lighting control				
			 Relay switching insert 5403 00	 Relay switching insert, 2-gang 5404 00	 Electronic switching insert 5405 00	 Universal LED dimming insert Standard 5400 00	 Universal LED dimming insert Komfort 5401 00
Top units	 Motion detector top unit 1.10 m Standard 	5373 ..	switching	switching a1 + a2, switch-on delay a2, delay time a2	switching	switching	switching
	 Motion detector top unit 1.10 m Komfort BT 	5374 ..	switching app operation	switching a1 + a2, switch-on delay a2, delay time a2, app operation	switching app operation	switching dimming app operation	switching dimming app operation
	 Motion detector top unit 2.20 m Standard 	5375 ..	switching	switching a1 + a2, switch-on delay a2, delay time a2	switching	switching	switching
	 Motion detector top unit 2.20 m Komfort BT 	5376 ..	switching app operation	switching a1 + a2, switch-on delay a2, delay time a2, app operation	switching app operation	switching dimming app operation	switching dimming app operation
	 Presence and motion detector 360° top unit BT 	5377 02	switching app operation	switching a1 + a2 switch-on delay a2, delay time a2, app operation	switching app operation	switching constant light control app operation	switching constant light control app operation
	 Room temperature controller Display	5393 ..	heating/cooling 3 time programs	---	heating/cooling 3 time programs	---	---
	 Room temperature controller BT 	5394 ..	heating/cooling flexible time programming, app operation	---	heating/cooling flexible time programming, app operation	---	---

 For mounting heights of up to 1.10 metres with an exclusively horizontally aligned detection range, and therefore no separate range limitation outdoors.

 Setting and operation with Gira System 3000 App.

 For mounting heights of up to 2.20 metres with an angled, vertically aligned detection range.

① Depends on the main unit to be controlled.

Inserts

Lighting control					Blind control		Heating control
							
Universal LED dimming insert Komfort, 2-gang	DALI Power control unit flush-mounted insert	2-wire auxiliary insert	3-wire auxiliary insert	Impulse insert with staircase-light automatic control switch	Blind control insert with auxiliary input	Blind control insert without auxiliary input	Room temperature controller insert with sensor connection
5402 00	5406 00	5408 00	5409 00	5410 00 0821 00	5414 00	5415 00	5395 00
switching a1 + a2 together	switching	---	switching on	switching on	---	---	---
switching dimming a1 + a2 together app operation	switching dimming app operation	---	switching on	switching on	---	---	---
switching a1 + a2 together	switching	---	switching on	switching on	---	---	---
switching, dimming a1 + a2 together, app operation	switching dimming app operation	---	switching on	switching on	---	---	---
switching, dimming a1 + a2 together, constant light control, app operation	switching constant light control app operation	---	switching on	switching on	---	---	---
---	---	---	---	---	---	---	heating/cooling 3 time programs floor temperature
---	---	---	---	---	---	---	heating/cooling flexible time programming. floor temperature

3.4 Auxiliary units

Auxiliary units are an easy and cost-effective way to extend your control options and offer a variety of operating options. For example, with an auxiliary unit you can extend the detection field of motion detectors or set up additional operating points to control lighting or shading. You can also implement group or central control of your entire shading system with one auxiliary unit.

Combining different top units and inserts and the various operating variants produces a large number of case variables, not all of which can be included in this system manual. We've put together the basic rules for using auxiliary units:

- Auxiliary units only ever have as many functions as the main unit and the top unit placed on it.
- 2-wire auxiliary inserts can only be combined with an operating top unit or operating top unit arrow symbols.
- Any number of 2-wire auxiliary inserts can be connected to a main unit.
- As an alternative to the 2-wire auxiliary insert with operating top unit, not-illuminated buttons can be used. The operation and setting options for the main and auxiliary units vary depending on the main unit.
- A maximum of ten 3-wire auxiliary inserts can be connected to one or more main units.
- The maximum cable length is 100 metres.
- If the auxiliary units and load line are laid separately, the number of 3-wire auxiliary units increases to ten.

Comparison of System 3000 auxiliary inserts

Property	2-wire auxiliary insert	3-wire auxiliary insert	Auxiliary insert for Universal LED rotary dimming insert
Neutral conductor	Only usable without neutral conductor (N)	Only usable with neutral conductor (N)	Only usable with neutral conductor (N)
Test button	No	No	No
Combinable with top unit	For operating top units with and without arrow symbols	All System 3000 top units (including operating top unit and operating top unit, 2-gang)	Cover with knob for dimmer
Number of auxiliary units on a main unit	Any amount	Max. 10	Max. 10
Number of main units on an auxiliary unit	1	Up to five main units (group control) Group control is not possible with the DALI Power control units.	1
Motion detector on the auxiliary unit with brightness evaluation	No	Yes	No, only cover with knob for dimmer

Compatibility of System 3000 with System 2000 auxiliary unit

Main unit	Auxiliary unit	Compatible
System 2000 switching or dimming insert	Rocker button	Yes
	System 3000 2-wire auxiliary insert	Yes
	System 3000 3-wire auxiliary insert	No
	System 3000 rotary auxiliary unit	No
System 3000 switching or dimming insert	Rocker button	Yes
	System 2000 2-wire auxiliary insert	Yes
	System 2000 3-wire auxiliary insert	No

3.4.1 3-wire auxiliary insert with motion detector

As soon as a top unit with a microcontroller (all top units except the operating top unit and operating top unit, 2-gang) is used on the main unit, a motion detector can also be used on the 3-wire auxiliary insert.

When the switch-on conditions (brightness, movement) are fulfilled, the lighting is switched on for two minutes of delay time.

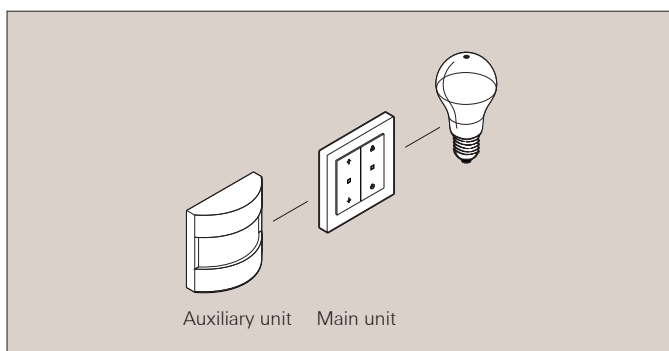

3.4.2 3-wire auxiliary insert with brightness evaluation

There is a motion detector on the main and auxiliary units. The brightness is also evaluated on the auxiliary unit.

Each motion detector decides on the basis of its set brightness threshold whether the lighting should be switched on.

The light is switched off when:

- no more movement is detected in the detection range and the delay time has elapsed or
- the ambient light is bright enough and the delay time has elapsed.

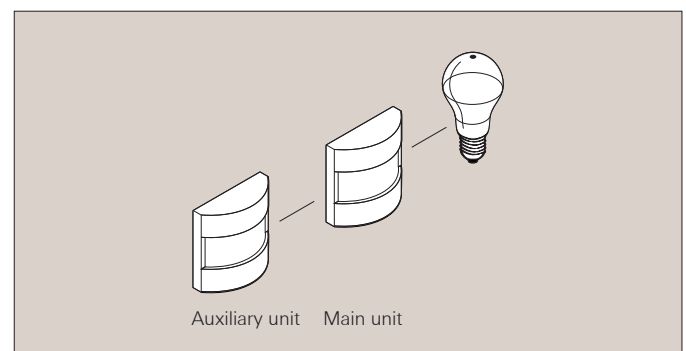

3.4.3 Central 3-wire auxiliary insert (group control)

- In System 3000, it is possible to switch on and off or dim several main units centrally using a 3-wire auxiliary insert.
- Selective switching on and off of the main units.
- A maximum of five main units, including System 3000 rotary, Mini and DRA dimmers.
- Not possible with DALI Power control unit, flush-mounted insert.

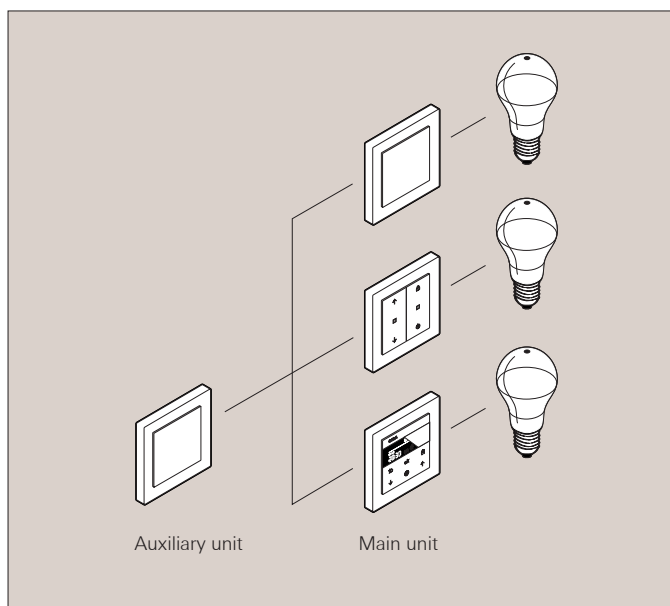

3.5 Misplacement protection

The intelligent Gira System 3000 top units can detect whether they have been placed back on the right type of insert or even on the same insert, for example, after being removed from the inserts during a renovation and collected in a box.

To be able to assign the top units to the correct inserts, the following rules apply:

1. Operating top unit, operating top unit, 2-gang and motion detector top unit Standard have no misplacement protection. They always immediately work on any suitable insert.
2. Intelligent top units without Bluetooth networking (e.g. blind timer and timer Display) have a misplacement protection feature that detects whether the top unit has been placed on a suitable insert type (functions: lighting or shading). For example, if the blind timer and timer Display was installed on a blind insert and is now plugged into a light insert, "Err" appears on the display. Pressing the "Up" and "Down" buttons simultaneously for more than four seconds will cancel the misplacement protection and the combination of the insert and the top unit will work again.
3. Intelligent top units with Bluetooth networking (e.g. motion detector top unit Komfort BT, blind timer and timer BT, presence and motion detector 360° top unit BT) etc. detect whether the top unit has been placed back on the insert with which the top unit was put into operation. If the top unit is not placed on the same insert as before, an error message is generated. This way, you can ensure that different top units of the same type but with differing configurations are placed back on their original insert. If the status LED flashes red three times, this means that the top unit was previously connected to another insert. The blind timer and timer Display and room temperature controller signal the misplacement protection by an indicator in the display.
4. Place the top unit on the associated insert or alternatively, reset the top unit by simultaneously pressing the operating buttons for switching, raising and lowering or dimming for more than four seconds.

3.6 Backward compatibility

If buildings are equipped with System 2000 and blind control and are now to be modernised with components from the new System 3000, the following principles apply:

- Installation buttons as an auxiliary unit do not have to be changed.
- System 2000 2-wire auxiliary insert (top unit and insert) do not have to be changed.
- System 2000 auxiliary insert for presence detectors and 3-wire automatic control switches can no longer be used and must be replaced by top units and inserts from the new System 3000. The main units must then also be replaced by System 3000 main units.
- In principle, the top units and inserts must always be from the same system.
- In an existing blind controller installation, available device combinations (top unit and insert) can be replaced by individual System 3000 combinations.

4 // System 3000 Lighting

4.1 Device overview

Inserts	Order no.
System 3000 universal LED dimming insert Standard	5400 00
System 3000 universal LED dimming insert Komfort	5401 00
System 3000 universal LED dimming insert Komfort, 2-gang	5402 00
System 3000 relay switching insert	5403 00
System 3000 relay switching insert, 2-gang	5404 00
System 3000 electronic switching insert	5405 00
System 3000 DALI Power control unit, flush-mounted insert	5406 00
System 3000 impulse insert	5410 00
System 3000 2-wire auxiliary insert	5408 00
System 3000 3-wire auxiliary insert	5409 00
System 3000 universal LED rotary dimming insert Standard	2450 00
System 3000 universal LED rotary dimming insert Komfort	2455 00
System 3000 rotary auxiliary insert for LED dimmer	2389 00
System 3000 universal LED dimmer Mini	2440 00
System 3000 universal LED dimmer DRA	2365 00
System 3000 universal LED power booster DRA	2383 00
Top units	Order no.
System 3000 operating top unit	5360 ..
System 3000 operating top unit arrow symbols	5361 ..
System 3000 touch top unit	5365 ..
System 3000 operating top unit, 2-gang	5362 ..
System 3000 operating top unit Memory arrow symbols	5363 ..
System 3000 blind timer and timer Display	5366 ..
System 3000 operating top unit BT	5368 ..
System 3000 blind timer and timer BT	5367 ..
eNet wireless operating top unit arrow symbols	5494 ..
eNet wireless operating top unit	5495 ..
eNet wireless operating top unit Memory arrow symbols	5492 ..
eNet wireless operating top unit Memory	5493 ..
System 3000 motion detector top unit 1.10 m Standard	5373 ..
System 3000 motion detector top unit 1.10 m Komfort BT	5374 ..
System 3000 motion detector top unit 2.20 m Standard	5375 ..
System 3000 motion detector top unit 2.20 m Komfort BT	5376 ..
System 3000 presence and motion detector 360° top unit BT	5377 02
Sensors	Order no.
System 3000 brightness and temperature sensor BT	5466 02

System 3000 relay switching insert

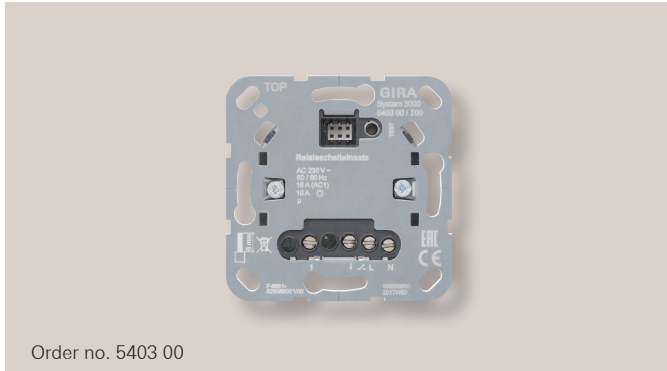

Order no. 5403 00

The relay switching insert switches different light sources such as LEDs, halogen light bulbs or fluorescent lamps and motors. In combination with a room temperature controller top unit, it can control electric floor heating systems and electrothermal servos. The TEST button with LED display can be used to conveniently set delay times if desired.

The switching insert can be installed in a commercially available device box (e.g. Kaiser 1055-02) in accordance with DIN 49073.

Functions at a glance:

- Delay times can be set when an operating top unit is used
- Auxiliary input for rocker button, 2 or 3-wire auxiliary insert
- When used as a room temperature controller insert, the auxiliary input is used to switch over to cooling mode.
- Suitable for switching the following loads per channel:
 - typ. 400 W HV LED lamps
 - typ. 500 W compact fluorescent lamp
 - 2,300 W light bulbs
 - 2,300 W HV halogen lamps
 - 1,200 VA fluorescent lamps, not compensated
 - 1,500 W Gira Tronic transformers
 - 1,000 VA wound transformer
 - 6 A switching current for motors
- Functions that can be set using the TEST button:
 - Switching on and off using short operation
 - Delay time: None, 1 min, 5 min, 30 min, 60 min
- AC 230 V, 50/60 Hz
- VDE mark
- Screw terminals

System 3000 relay switching insert, 2-gang

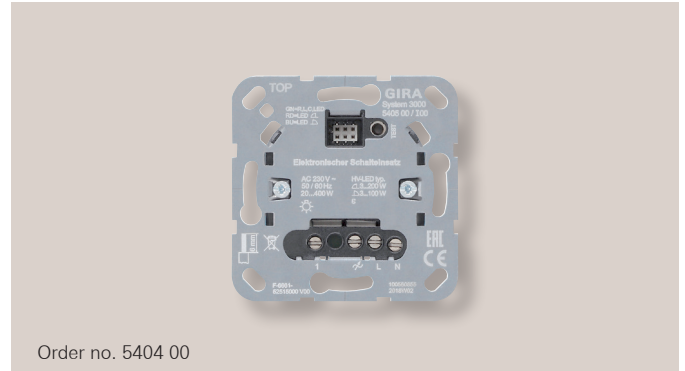

Order no. 5404 00

In combination with an operating top unit, 2-gang, the relay switching insert, 2-gang can switch two independent outputs with different light sources, e.g. LEDs, halogen lamps, fluorescent lamps or motors. A time function can be activated for the second output. If a time function has been set, it switches off after the set time has elapsed. The time function starts as soon as the output is switched on.

In combination with an operating top unit, both outputs are switched together. A switch-on delay of 3 minutes can be activated and a delay time set for the second output.

Operation with other System 3000 top units (motion detectors, timers, etc.) is essentially the same as operation with an operating top unit.

Functions at a glance:

- For output 2:
 - Time function when an operating top unit, 2-gang is used
 - Switch-on delay (3 minutes) and delay time can be set when an operating top unit is used
- Auxiliary input for rocker button, 2 or 3-wire auxiliary insert
- Suitable for switching the following loads per channel:
 - typ. 400 W HV LED lamps
 - typ. 500 W compact fluorescent lamp
 - 1500 W light bulbs
 - 1,500 W HV halogen lamps
 - 750 VA fluorescent lamps, not compensated
 - 1000 W Gira Tronic transformers
 - 625 VA wound transformer
 - 3 A switching current for motors
- Functions that can be set using the TEST button:
 - Delay time/time function: None, 1 min, 5 min, 30 min, 60 min
- AC 230 V, 50/60 Hz
- VDE mark
- Screw terminals

System 3000 electronic switching insert

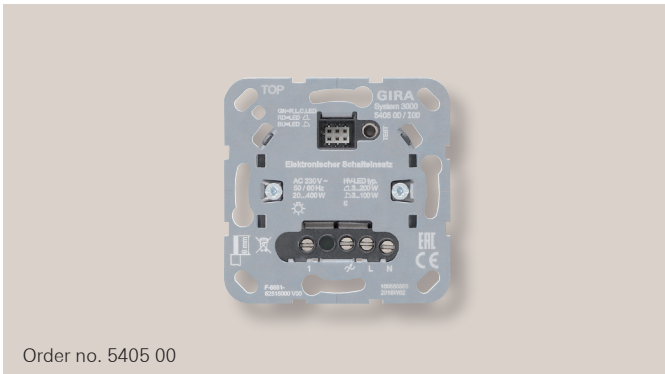

The electronic switching insert can be operated with or without neutral conductor.

In the event of operation with a neutral conductor, the electronic switching insert is supplied via the external conductor and neutral conductor, and therefore there is no leading or trailing edge. It is not necessary to set an operating mode. Control of electrothermal servos in combination with a room temperature controller top unit is possible.

In the event of operation without a neutral conductor, the electronic switching insert is supplied via the external conductor and the connected load, and therefore there is no leading or trailing edge. The corresponding operating mode is set automatically or manually to match the load. The set operating mode is indicated by an LED. The electronic switching insert can be installed in a commercially available device box (e.g. Kaiser 1055-02) in accordance with DIN 49073.

Functions at a glance:

- Switch-on with soft start, which preserves the life of the lamp
- Auxiliary input for rocker button, 2 or 3-wire auxiliary insert
- Electronic short circuit protection with permanent deactivation after seven seconds at the latest, reversible
- Electronic excess-temperature protection
- Suitable for switching the following loads:
 - typ. 3 to 100 W HV LED lamps
 - typ. 3 up to 100 W compact fluorescent lamp
 - 20 to 400 W light bulbs
 - 20 to 400 W HV halogen lights
 - 20 to 400 W Gira Tronic transformer
 - typ. 20 to 100 W electronic transformer with LV LED
 - 20 to 400 VA wound transformer
 - typ. 20 to 100 VA wound transformer with LV LED
 - In Trailing Edge Connected Load operating mode for HV LED lamps typ. 3 to 200 W, electronic transformers with LV LED typ. 20 to 200 W
 - 1 to 10 number of thermal servos (order no.: 2169 00)
- AC 230 V, 50/60 Hz
- VDE mark
- Screw terminals

System 3000 impulse insert

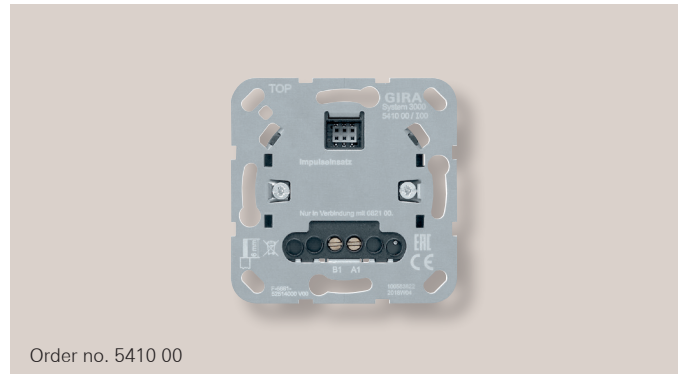

With the impulse insert, you can set up staircase lighting controls. In combination with an operating top unit or motion detector, you can control the light manually or automatically on a floor-by-floor basis.

In combination with the DRA automatic staircase light timer, you can convert existing staircase installations to automatic lighting control without having to rewire.

The impulse insert can be installed in a commercially available device box (e.g. Kaiser 1055-02) in accordance with DIN 49073.

Functions at a glance:

- Installation or retrofitting of motion detectors on the staircase
- Simple retrofitting of existing 3 or 4-wire installations
- Operation with the DRA staircase light timer, order no. 0821 00
- Can be combined with System 3000 operating top units, motion detectors, and presence and motion detectors
- Post-triggering of the delay time by repeatedly pressing the operating top unit or by repeated detection by the motion detector
- AC 230 V, 50/60 Hz
- VDE mark
- Screw terminals
- Power systems: see operating instructions for the DRA staircase light timer, order no. 0821 00

With the universal LED dimming insert Standard, you can switch lighting on/off and dim lighting. As a universal LED dimmer, the dimmer automatically adjusts to leading or trailing edge. Operation with or without a neutral conductor is possible.

System 3000 universal LED dimming insert Standard

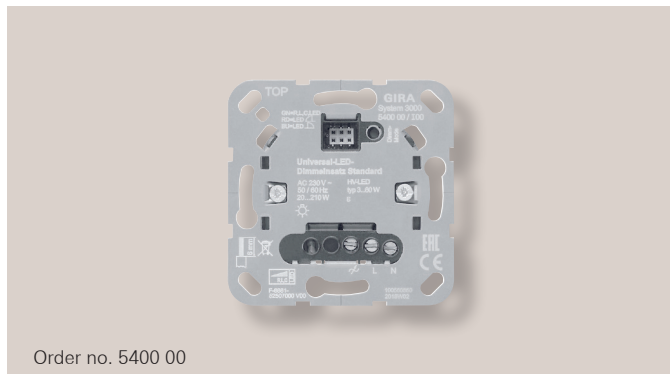

Order no. 5400 00

You can conveniently adjust the dimmer via a dimming mode button with LED display. The universal LED dimming insert Standard can be installed in a commercially available device box (e.g. Kaiser 1055-02) in accordance with DIN 49073.

Functions at a glance:

- Automatic or manual setting of the operating mode suitable for the load
- Switch-on with soft start, which preserves the life of the lamp
- Minimum brightness can be set
- Switch-on brightness or last brightness level can be saved
- Connecting auxiliary units is not possible
- Electronic short-circuit protection with permanent deactivation after seven seconds at the latest, reversible
- Electronic excess-temperature protection
- Suitable for switching the following loads:
 - typ. 3 to 60 W HV LED lamps
 - typ. 3 to 60 W compact fluorescent lamp
 - 20 to 210 W light bulbs
 - 20 to 210 W HV halogen
 - 20 to 210 W Gira Tronic transformer
 - typ. 20 to 60 W electronic transformer with LV LED
 - 20 to 210 VA wound transformer
 - typ. 20 to 60 VA wound transformer with LV LED
 - In Trailing Edge Connected Load operating mode for HV LED lamps typ. 3 to 120 W, electronic transformers with LV LED typ. 20 to 120 W
- AC 230 V, 50/60 Hz
- VDE mark
- Screw terminals

System 3000 universal LED dimming insert Komfort

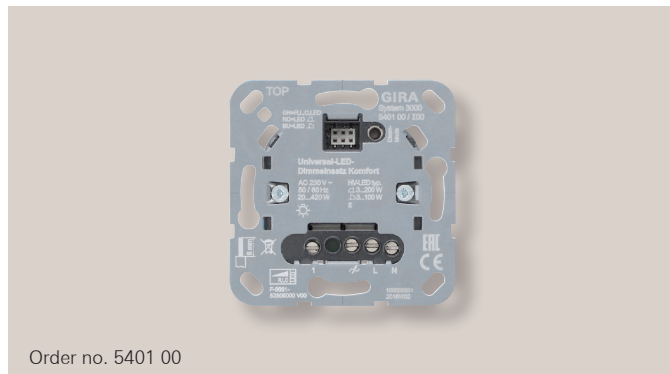

Order no. 5401 00

With the universal LED dimming insert Komfort, you can switch lighting on/off and dim lighting. As a universal LED dimmer, you can set it specifically to leading edge or trailing edge. Operation with or without a neutral conductor is possible. It has an auxiliary input for the 2-wire, 3-wire auxiliary insert and rocker button.

You can conveniently adjust the dimmer via a dimming mode button with LED display. The universal LED dimming insert Komfort can be installed in a commercially available device box (e.g. Kaiser 1055-02) in accordance with DIN 49073.

Functions at a glance:

- Automatic or manual setting of the operating mode suitable for the load
- Switch-on with soft start, which preserves the life of the lamp
- Minimum brightness can be set
- Switch-on brightness or last brightness level can be saved
- Auxiliary input for rocker button, 2 or 3-wire auxiliary insert
- Electronic short circuit protection with permanent deactivation after seven seconds at the latest, reversible
- Electronic excess-temperature protection
- Suitable for switching the following loads:
 - typ. 3 to 100 W HV LED lamps
 - typ. 3 up to 100 W compact fluorescent lamp
 - 20 to 420 W light bulbs
 - 20 to 420 W HV halogen
 - 20 to 420 W Gira Tronic transformer
 - typ. 20 to 100 W electronic transformer with LV LED
 - 20 to 420 VA wound transformer
 - typ. 20 to 100 VA wound transformer with LV LED
 - In Trailing Edge Connected Load operating mode for HV LED lamps typ. 3 to 400 W, electronic transformers with LV LED typ. 20 to 200 W
- AC 230 V, 50/60 Hz
- VDE mark
- Screw terminals

System 3000 universal LED dimming insert Komfort, 2-gang

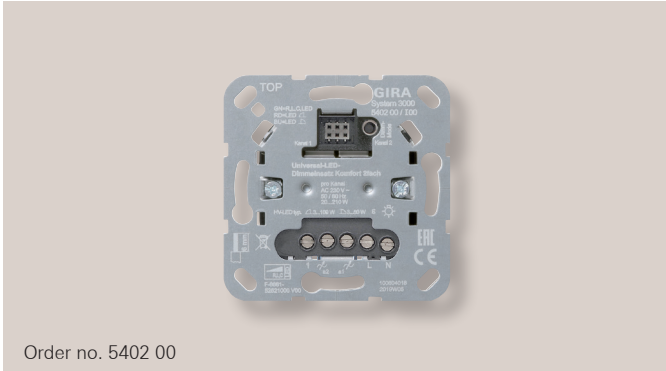

Order no. 5402 00

With the universal LED dimming insert Komfort, 2-gang you can switch and dim two lights independently of each other. As a universal LED dimmer, you can set it specifically, for each individual output, to leading edge or trailing edge. Operation with or without a neutral conductor is possible. With an operating top unit, 2-gang, each output can be controlled individually, while with a single operating top unit, both outputs are operated together.

Operation with other System 3000 top units (motion detectors, timers, etc.) is essentially the same as operation with an operating top unit.

You can conveniently adjust the dimmer via a dimming mode button with LED display. The universal LED dimming insert Komfort, 2-gang can be installed in a commercially available device box (e.g. Kaiser 1055-02) in accordance with DIN 49073.

Functions at a glance:

- Two independent outputs for two light groups
- Automatic or manual setting of the operating mode suitable for the load
- Switch-on with soft start, which preserves the life of the lamp
- Minimum brightness can be set
- Switch-on brightness or last brightness level can be saved
- Auxiliary input for rocker button, 2 or 3-wire auxiliary insert
- Electronic short circuit protection with permanent deactivation after seven seconds at the latest, reversible
- Electronic excess-temperature protection
- Suitable for switching the following loads:
 - typ. 3 to 50 W HV LED lamps
 - typ. 3 up to 50 W compact fluorescent lamp
 - 20 to 210 W light bulbs
 - 20 to 210 W HV halogen
 - 20 to 210 W Gira Tronic transformer
 - typ. 20 to 50 W electronic transformer with LV LED
 - 20 to 210 VA wound transformer
 - typ. 20 to 50 VA wound transformer with LV LED
 - In Trailing Edge Connected Load operating mode for HV LED lamps typ. 3 to 100 W, electronic transformers with LV LED typ. 20 to 100 W
- AC 230 V, 50/60 Hz
- VDE mark
- Screw terminals

System 3000 DALI Power control unit flush-mounted insert

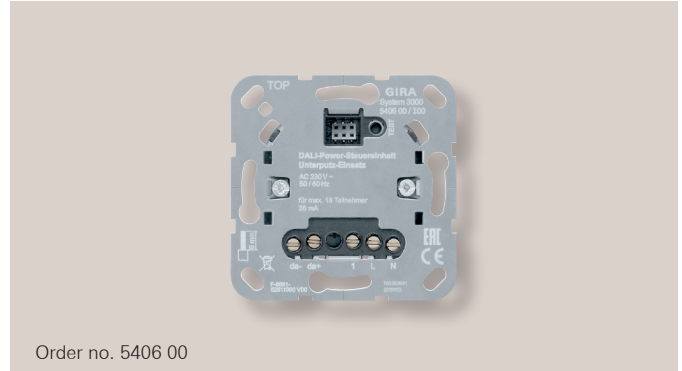

Order no. 5406 00

With the single-channel DALI Power control unit flush-mounted insert, you can control lights with a DALI interface and DALI ballasts with or without Tunable White function.

Operation is via the Gira operating top units or timers or via motion detectors and presence detectors.

With an operating top unit, 2-gang, the left rocker functions like the operating top unit. The right rocker is used to directly set the colour temperature.

The DALI Power control unit flush-mounted insert can be installed in a commercially available device box (e.g. Kaiser 1055-02) in accordance with DIN 49073.

Functions at a glance:

- Operation with mains voltage (active operation)
- In active operation, the device supplies the necessary control current for 18 DALI devices
- Number of DALI devices can be expanded to 72 by connecting up to four active DALI inserts in parallel
- Auxiliary input for rocker button, 2 or 3-wire auxiliary insert
- Colour temperature setting for lights with DALI device type 8 for Tunable White in accordance with IEC 62386-209
- Minimum brightness, coolest and warmest colour temperature can be saved
- Switch on with the last brightness/colour temperature set, or a saved brightness/colour temperature.
- Colour temperature setting 2,000 to 10,000 K
- AC 230 V, 50/60 Hz
- With operating top unit, 2-gang: Adjustment of colour temperature using right-hand rocker
- VDE mark
- Screw terminals

System 3000 universal LED dimmer Mini



With the universal LED dimmer Mini, you can switch lighting on/off and dim lighting. As a universal LED dimmer, the dimmer automatically sets itself to leading edge or trailing edge. Operation with or without a neutral conductor is possible.

The universal LED dimmer Mini is operated via a 2-wire or 3-wire auxiliary insert with operating top unit, rocker button or a rotary auxiliary insert for LED dimmers.

The universal LED dimmer Mini can be installed in a commercially available device box (e.g. Kaiser 1055-02) in accordance with DIN 49073, in combination with a suitable cover.

A surface-mounted housing (installation adapter mini housing, order no. 5429 00) is available for installation in false ceilings, on the wall or on top-hat rails.

Functions at a glance:

- Operates according to the leading edge or trailing edge principle
- Automatic or manual setting of the operating mode to match the load
- Set operating mode is indicated by an LED
- Switch-on with soft start, which preserves the life of the lamp
- Switch-on brightness or last brightness level can be saved
- Minimum brightness can be set
- Electronic short-circuit protection with permanent deactivation after seven seconds at the latest, reversible
- Electronic excess-temperature protection
- Suitable for switching the following loads:
 - typ. 3 to 50 W HV LED lamps
 - typ. 3 up to 50 W compact fluorescent lamp
 - 20 to 210 W light bulbs
 - 20 to 210 W HV halogen
 - 20 to 210 W Gira Tronic transformer
 - typ. 20 to 50 W electronic transformer with LV LED
 - 20 to 210 VA wound transformer
 - typ. 20 to 50 VA wound transformer with LV LED
 - In Trailing Edge Connected Load operating mode for HV LED lamps typ. 3 to 100 W, electronic transformers with LV LED typ. 20 to 100 W
- AC 230 V, 50/60 Hz
- VDE mark
- Screw terminals

System 3000 universal LED rotary dimming insert Standard



With the universal LED rotary dimming insert Standard, you can switch lighting on/off and dim lighting. As a universal LED dimmer, the dimmer automatically adjusts to leading or trailing edge. Operation with or without a neutral conductor is possible.

The universal LED rotary dimming insert Standard can be installed in a commercially available device box (e.g. Kaiser 1055-02) in accordance with DIN 49073.

Functions at a glance:

- Automatic setting of the operating mode to match the load
- Switch-on with soft start, which preserves the life of the lamp
- Minimum brightness can be set
- Switch-on brightness or last brightness level can be saved
- Electronic short-circuit protection with permanent deactivation after seven seconds at the latest, reversible
- Electronic excess-temperature protection
- Suitable for switching the following loads:
 - typ. 3 to 60 W HV LED lamps
 - typ. 3 to 60 W compact fluorescent lamp
 - 20 to 210 W light bulbs
 - 20 to 210 W HV halogen
 - 20 to 210 W Gira Tronic transformer
 - typ. 20 to 60 W electronic transformer with LV LED
 - 20 to 210 VA wound transformer
 - typ. 20 to 60 VA wound transformer with LV LED
 - If the dimmer has been calibrated to trailing edge, the connected load for HV LED lamps is typ. 3 to 120 W and electronic transformers with LV LED lamps typ. 20 to 120 W.
- AC 230 V, 50/60 Hz
- VDE mark
- Screw terminals

System 3000 universal LED rotary dimming insert Komfort

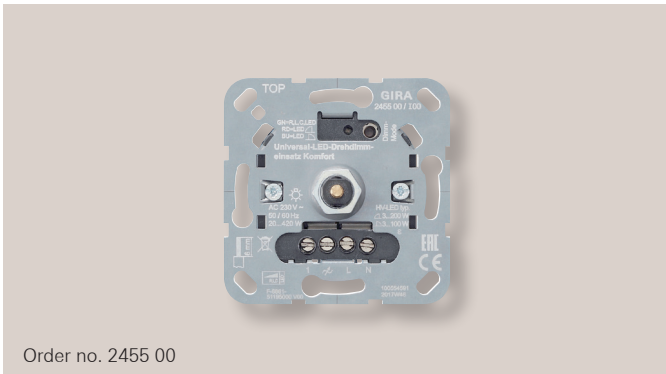

With the universal LED rotary dimming insert Komfort, you can switch lighting on/off and dim lighting. As a universal LED dimmer, you can set it specifically to leading edge or trailing edge. Operation with or without a neutral conductor is possible.

You can conveniently adjust the dimmer via a dimming mode button with LED display. The universal LED rotary dimming insert Komfort can be installed in a commercially available device box (e.g. Kaiser 1055-02) in accordance with DIN 49073.

Functions at a glance:

- Automatic or manual setting of the operating mode suitable for the load
- Switch-on with soft start, which preserves the life of the lamp
- Minimum brightness can be set
- Switch-on brightness or last brightness level can be saved
- Auxiliary input for rocker button, 2 or 3-wire auxiliary insert
- Electronic short circuit protection with permanent deactivation after seven seconds at the latest, reversible
- Electronic excess-temperature protection
- Suitable for switching the following loads:
 - typ. 3 to 100 W HV LED lamps
 - typ. 3 up to 100 W compact fluorescent lamp
 - 20 to 420 W light bulbs
 - 20 to 420 W HV halogen
 - 20 to 420 W Gira Tronic transformer
 - typ. 20 to 100 W electronic transformer with LV LED
 - 20 to 420 VA wound transformer
 - typ. 20 to 100 VA wound transformer with LV LED
 - In Trailing Edge Connected Load operating mode for HV LED lamps typ. 3 to 400 W, electronic transformers with LV LED typ. 20 to 400 W
- AC 230 V, 50/60 Hz
- VDE mark
- Screw terminals

System 3000 3-wire rotary auxiliary insert for LED dimmer

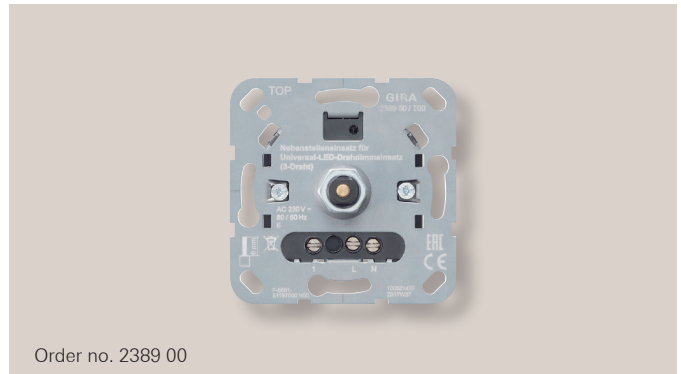

With the 3-wire rotary auxiliary insert, you can control the universal LED rotary dimming insert Komfort, universal LED dimming insert Komfort, universal LED dimmer Mini and the universal LED dimmer DRA.

The 3-wire rotary auxiliary insert for LED dimmer can be installed in a commercially available device box (e.g. Kaiser 1055-02) in accordance with DIN 49073.

Functions at a glance:

- Operation identical to the universal LED rotary dimming insert
- A maximum of five rotary auxiliary inserts on one or more main units can be connected
- Maximum total cable length 100 m
- AC 230 V, 50/60 Hz
- VDE mark
- Screw terminals

System 3000 2-wire auxiliary insert

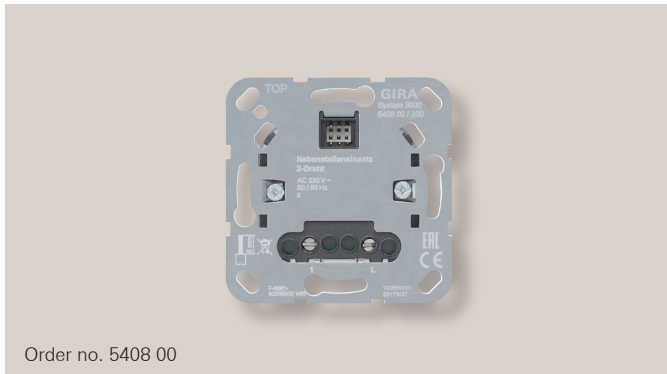

System 3000 3-wire auxiliary insert

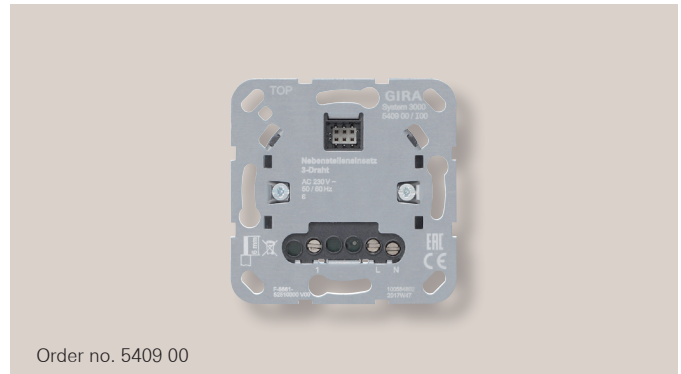

With the 2-wire auxiliary insert, you can switch lighting on/off and dim your lighting. In total, the auxiliary unit always has exactly as many functions as the top unit placed at the main unit. Operation is in combination with an operating top unit. The 2-wire rotary auxiliary insert can be installed in a commercially available device box (e.g. Kaiser 1055-02) in accordance with DIN 49073.

Functions at a glance:

- Can only be combined with operating top units with and without arrow symbols
- Set-up of additional operating units for the control of System 3000
- Any number of 2-wire auxiliary inserts can be connected to one main unit
- Maximum total cable length 100 metres
- AC 230 V, 50/60 Hz
- VDE mark
- Screw terminals

The 3-wire auxiliary insert offers a wide variety of functions depending on the top unit and insert used on the main unit. Overall, the auxiliary unit always has just as many functions as the top unit placed on the main unit. Operation is in combination with the System 3000 top units. The 3-wire rotary auxiliary insert can be installed in a commercially available device box (e.g. Kaiser 1055-02) in accordance with DIN 49073.

Functions at a glance:

- Can be combined with all top units
- Different applications are possible due to the various potential combinations of System 3000 top units and inserts
- Extension of the detection field of motion detectors
- Set-up of additional operating points for control of System 3000
- A maximum of ten 3-wire auxiliary inserts can be connected to one or more main units; if the auxiliary unit and load lines are laid separately, up to ten 3-wire auxiliary inserts can be connected
- Maximum total cable length 100 metres
- AC 230 V, 50/60 Hz
- VDE mark
- Screw terminals

System 3000 universal LED dimmer DRA



With the universal LED dimmer DRA, you can switch lighting on/off and dim lighting. As a universal LED dimmer, the dimmer automatically adjusts to leading or trailing edge.

One advantage: when renovating, you do not have to lay any new lines, but can simply install directly on the existing installation. The required components disappear into a central sub-distribution.

The universal LED dimmer DRA is operated via a 2-wire or 3-wire auxiliary insert with operating top unit, a rocker button or a rotary auxiliary insert for LED dimmers.

The DRA dimmer is mounted in the sub-distribution on top-hat rails according to DIN EN 60715.

Functions at a glance:

- Operates according to the leading edge or trailing edge principle
- Automatic or manual setting of the operating mode suitable for the load
- Set operating mode is indicated by an LED
- Switch-on with soft start, which preserves the life of the lamp
- Switch-on brightness or last brightness level can be saved
- Minimum brightness can be set
- Electronic short circuit protection with permanent deactivation after seven seconds at the latest, reversible
- Electronic excess-temperature protection
- Suitable for switching the following loads:
 - typ. 3 to 100 W HV LED lamps
 - typ. 3 up to 100 W compact fluorescent lamp
 - 20 to 420 W light bulbs
 - 20 to 420 W HV halogen
 - 20 to 420 W Gira Tronic transformer
 - typ. 20 to 100 W electronic transformer with LV LED
 - 20 to 420 VA wound transformer
 - typ. 20 to 100 VA wound transformer with LV LED
 - In Trailing Edge Connected Load operating mode for HV LED lamps typ. 3 to 400 W, electronic transformers with LV LED typ. 20 to 200 W
- AC 230 V, 50/60 Hz
- VDE mark
- Screw terminals

System 3000 universal LED power booster DRA



With the universal LED power booster DRA, you can expand your dimmer in a modular fashion, depending on your power requirements. Depending on the dimmer, different numbers of power boosters can be connected. This allows you to conveniently switch and dim large LED loads. Operation of the power booster is via upstream dimmer.

The universal LED power booster DRA is mounted in the sub-distribution on top-hat rails according to DIN EN 60715.

Functions at a glance:

- Several universal LED power booster DRAs can be connected to one dimmer
- Total power of the connected loads is divided between dimmers and power boosters
- Connected loads are supplied via a common load line
- Electronic excess-temperature protection
- The maximum load and number of power boosters depends on the dimmer (see reference list in the user manual of the universal LED power booster DRA).
Suitable for the following loads:
 - 50 to 100 W HV LED lamps leading edge
 - 200 W HV LED lamps trailing edge
 - 210 to 420 W light bulbs
 - 210 to 420 W HV halogen
 - 210 to 420 W Gira Tronic transformer
 - 210 to 420 VA wound transformer
- AC 230 V, 50/60 Hz
- VDE mark
- Screw terminals

System 3000 motion detector top unit 1.10 m Standard



Order no. 5373 ..

The motion detector top unit regulates the lighting depending on motion and brightness. It automatically switches on the lighting if there is movement in the detection field and if it is dark enough.

The lighting is switched off

- when no more movement is detected and the two-minute delay time has elapsed

or

- when it is light enough again and the two-minute delay time has elapsed.

This is convenient and saves energy. Thanks to the special lens design, the motion detector top unit has a large detection field.

Functions at a glance:

- Automatic light switching, depending on thermal movement and ambient brightness
- Detection range 180°
- Clip-on panel to limit the detection range
- Extended detection range via auxiliary units
- Switch-on brightness and sensitivity can be adjusted
- Mounting height 1.10 metres
- In Gira TX_44 also IP44 protection against splash water

- Detection field:

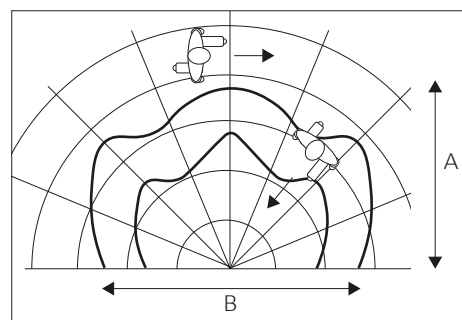

	A x B	
1.10 m Sensitivity		
25%	≈ 8 x 11 m	≈ 2 x 4 m
50%	≈ 13 x 20 m	≈ 5 x 6 m
75%	≈ 26 x 30 m	≈ 6 x 9 m
100%	≈ 32 x 38 m	≈ 11 x 14 m

System 3000 motion detector top unit 2.20 m Standard



The motion detector top unit regulates the lighting depending on motion and brightness. It automatically switches on the lighting if there is movement in the detection field and if it is dark enough.

The lighting is switched off

- when no more movement is detected and the two-minute delay time has elapsed
- or
- when it is light enough again and the two-minute delay time has elapsed.

This is convenient and saves energy. The motion detector top unit has a large detection field, which also includes the area below the detector thanks to the special lens design. At the intended mounting height of 2.20 metres, e.g. mounted over a door, the lighting is switched on upon when someone takes their first step through the door.

Functions at a glance:

- Automatic light switching, depending on thermal movement and ambient brightness
- Detection range 180°
- Extended detection range via auxiliary units
- Switch-on brightness and sensitivity can be adjusted
- Mounting height 2.20 metres or 1.10 metres
- In Gira TX_44 also IP44 protection against splash water

- Detection field:

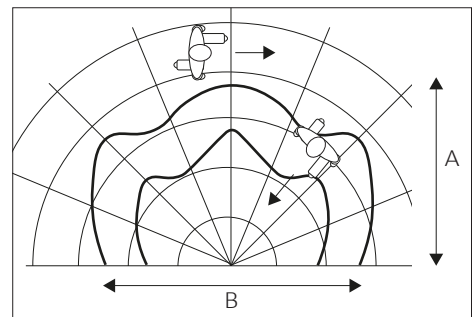

	A x B	
2.20 m Sensitivity		
25%	≈ 7 x 12 m	≈ 3 x 2 m
50%	≈ 11 x 13 m	≈ 4 x 4 m
75%	≈ 13 x 15 m	≈ 6 x 5 m
100%	≈ 15 x 20 m	≈ 9 x 9 m

	A x B	
1.10 m Sensitivity		
25%	≈ 7 x 9 m	≈ 1 x 2 m
50%	≈ 8 x 10 m	≈ 3 x 4 m
75%	≈ 9 x 12 m	≈ 4 x 6 m
100%	≈ 10 x 18 m	≈ 5 x 7 m

System 3000 motion detector top unit 1.10 m Komfort BT



The motion detector top unit regulates the lighting depending on motion and brightness. It automatically switches on the lighting if there is movement in the detection field and if it is dark enough.

The lighting is switched off

- when no more movement is detected and the set delay time has elapsed
- or
- when it is light enough again and the set delay time has elapsed.

This is convenient and saves energy. Thanks to the special lens design, the motion detector top unit has a large detection field.

You can set this easily using your smartphone and the Gira System 3000 App.

Functions at a glance:

- Automatic light switching, depending on thermal movement and ambient brightness
- Detection range 180°
- Clip-on panel to limit the detection range
- Extended detection range via auxiliary units
- Switch-on brightness, delay time and sensitivity can be adjusted
- Staircase function with switch-off pre-warning
- Optimised burglary prevention through presence simulation
- Alarm function
- In combination with a dimming insert, switching on is possible with the last set brightness or saved switch-on brightness, as well as setting a basic light or night light function.
- Settings with smartphone and Gira System 3000 App
- Sliding switch for permanent On/Off
- Activation of the pairing mode for teaching into the Gira System 3000 App
 - Slide the sliding switch to the ON/AUTO position for more than four seconds.
- Mounting height 1.10 metres
- In Gira TX_44 also IP44 protection against splash water

- Detection field:

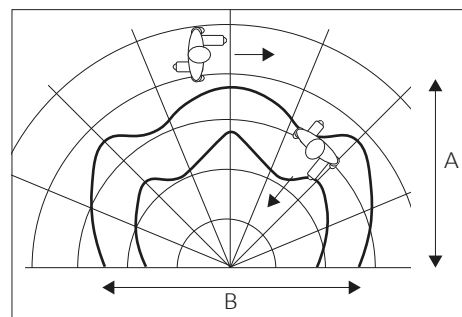

	A x B	
1.10 m Sensitivity		
25%	≈ 8 x 11 m	≈ 2 x 4 m
50%	≈ 13 x 20 m	≈ 5 x 6 m
75%	≈ 26 x 30 m	≈ 6 x 9 m
100%	≈ 32 x 38 m	≈ 11 x 14 m

System 3000 motion detector top unit 2.20 m Komfort BT



The motion detector top unit regulates the lighting depending on motion and brightness. It automatically switches on the lighting if there is movement in the detection field and if it is dark enough.

The lighting is switched off

- when no more movement is detected and the set delay time has elapsed
- or
- when it is light enough again and the set delay time has elapsed.

This is convenient and saves energy. The motion detector top unit has a large detection field, which also includes the area below the detector thanks to the special lens design. At the intended mounting height of 2.20 metres, e.g. mounted over a door, the lighting is switched on upon when someone takes their first step through the door.

You can set this easily using your smartphone and the Gira System 3000 App.

Functions at a glance:

- Automatic light switching, depending on thermal movement and ambient brightness
- Detection range 180°
- Extended detection range via auxiliary units
- Switch-on brightness, delay time and sensitivity can be adjusted
- Staircase function with switch-off pre-warning
- Optimised burglary prevention through presence simulation
- Alarm function
- In combination with a dimming insert, switching on is possible with the last set brightness or saved switch-on brightness, as well as setting a basic light or night light function.
- Settings with smartphone and Gira System 3000 App
- Button for permanent On/Off
- Activation of the pairing mode for teaching into the Gira System 3000 App
 - To do this, the ON/AUTO button must be pressed for more than four seconds
- Mounting height 2.20 metres or 1.10 metres
- In Gira TX_44 also IP44 protection against splash water

- Detection field:

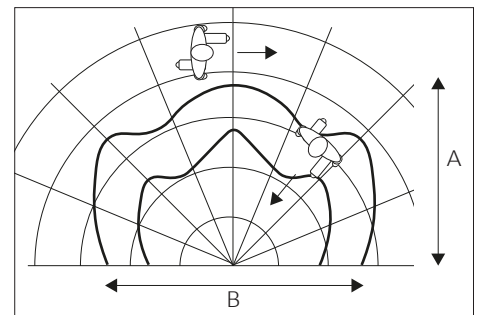

	A x B	
2.20 m Sensitivity		
25%	≈ 7 x 12 m	≈ 3 x 2 m
50%	≈ 11 x 13 m	≈ 4 x 4 m
75%	≈ 13 x 15 m	≈ 6 x 5 m
100%	≈ 15 x 20 m	≈ 9 x 9 m

	A x B	
1.10 m Sensitivity		
25%	≈ 7 x 9 m	≈ 1 x 2 m
50%	≈ 8 x 10 m	≈ 3 x 4 m
75%	≈ 9 x 12 m	≈ 4 x 6 m
100%	≈ 10 x 18 m	≈ 5 x 7 m

System 3000 presence and motion detector 360° top unit BT



The presence and motion detector 360° top unit BT controls the lighting in indoor areas depending on motion and brightness. It switches on the lighting automatically if there is motion in the detection field or if it is dark enough.

The lighting is switched off

- when no more movement is detected and the set delay time has elapsed
- or
- when it is light enough again and the set delay time has elapsed.

This is convenient and saves energy. The presence and motion detector 360° top unit BT has a large detection field thanks to the special lens design. Mounting heights of up to six metres allow for use in corridors or on staircases.

You can set this easily using your smartphone and the Gira System 3000 App.

Functions at a glance:

- Automatic light switching, depending on brightness and motion
- 360° detection range for mounting heights up to six metres
- Three independent PIR sensors that are individually adjustable
- Clip-on panel to limit the detection range
- Extension of the detection range by grouping up to ten devices
- Staircase function with switch-off pre-warning
- Optimised burglary prevention through presence simulation
- Constant light control in combination with dimming inserts
- Can be used as a security light and as a presence detector
- Alarm function
- Night light function
- Basic brightness can be set
- Settings with smartphone and Gira System 3000 App
- Mounting height three metres:
 - Detection field – tangential direction of movement: Ø 20 metres
 - Detection field – radial direction of movement: Ø 12 metres

System 3000 operating top unit System 3000 operating top unit arrow symbols



The operating top unit is a single-channel top unit for System 3000 inserts.

It can be operated at the top, bottom and additionally across the entire surface.

Functions at a glance:

- Lighting control with corresponding inserts
- Shading control with corresponding inserts
- Continuous operating concept
- Top unit for 2-wire or 3-wire auxiliary insert

System 3000 operating top unit, 2-gang

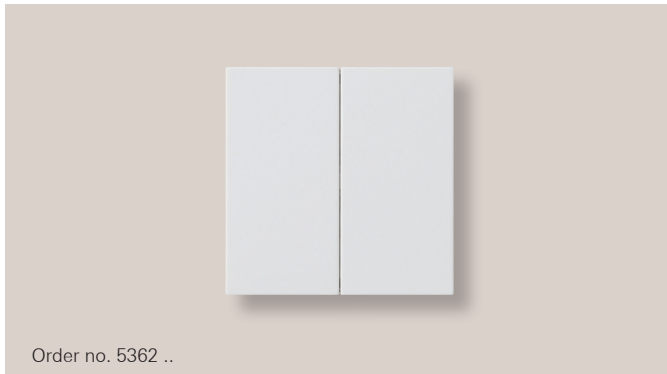

The operating top unit, 2-gang is a System 3000 2-channel top unit. It is suitable for all 2-channel inserts. Each rocker operates one channel and can be operated at the top, bottom or additionally across the entire surface.

Functions at a glance:

- Lighting control with corresponding 2-channel inserts
- Continuous operating concept
- Top unit for 3-wire auxiliary insert
- Setting the colour temperature with the right-hand rocker on the DALI Power control unit flush-mounted insert.

System 3000 touch top unit



The touch top unit is a single-channel top unit for all System 3000 inserts. It consists of a capacitive touch surface with an LED light bar as a status display in the typical Gira design. It is operated by lightly touching or swiping the touch surface.

Functions at a glance:

- Lighting control with corresponding inserts
- Shading control with corresponding inserts
- Continuous operating concept
- Top unit for 3-wire auxiliary insert
- Three brightness values can be saved with System 3000 dimming insert
- The runtime and an individual intermediate position can be saved using the System 3000 blind control insert
- Blocking function, with System 3000 blind control insert
- Status display using LED light bars for indicating the brightness or hanging position
- Night mode, i.e. the status display is not permanently illuminated

System 3000 operating top unit Memory arrow symbols

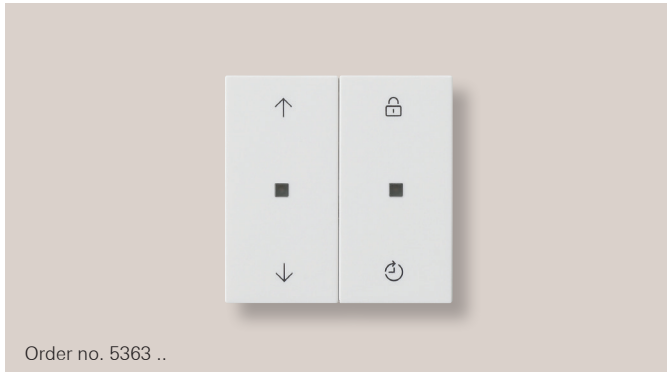

The operating top unit Memory is a single-channel top unit for System 3000 inserts. The top unit consists of a split rocker that looks like a rocker, 2-gang. Each side of the rocker is assigned a colour LED, which serves as a function display, status display and orientation light. The rocker can be operated at the top, bottom and additionally across the entire surface.

Functions at a glance:

- Lighting control with corresponding inserts
- Shading control with corresponding inserts
- Continuous operating concept
- Top unit for 3-wire auxiliary insert
- Operation is both manual and automatic
- Night mode, i.e. the function and status LED lights are not permanently illuminated
- Blocking function to deactivate all automatic, auxiliary unit and Memory functions
- Contains a memory function with two switching times that are repeated every 24 hours

System 3000 blind timer and timer Display



The blind timer and timer Display is a single-channel top unit for System 3000 inserts. It consists of a capacitive touch surface in the typical Gira design with an illuminated display.

Functions at a glance:

- Lighting control with corresponding inserts
- Shading control with corresponding inserts
- Top unit for 3-wire auxiliary insert
- Menu control, dialogue-led
- Two time blocks: Mon to Fri, Sat to Sun:
 - For switching and dimming inserts, a time block consists of two On/Off time combinations
 - For blind inserts, one time block consists of one Up/Down time combination
- Astro function:
 - 18 countries can be selected
 - Setting a time difference for morning and evening
- Quick save: Adopting the current time as the switching time
- Automatic setting of summer and winter time, which can be switched off by the user
- Illuminated segment display: Enables reliable reading in dark installation locations
- Touch-sensitive surface: Operation by six operating surfaces with printed symbols
- Evaluation of auxiliary units
- Display switches off after two minutes or switches to permanent display of the time
- Blocking function to deactivate automatic functions, auxiliary units and time programs
- Power failure: In the event of a power failure, the time and date are saved for four hours. All other values are saved in power outage safe mode
- Fast switching between automatic and manual actuation
- Display of the next switching time or raising/lowering time

System 3000 operating top unit BT

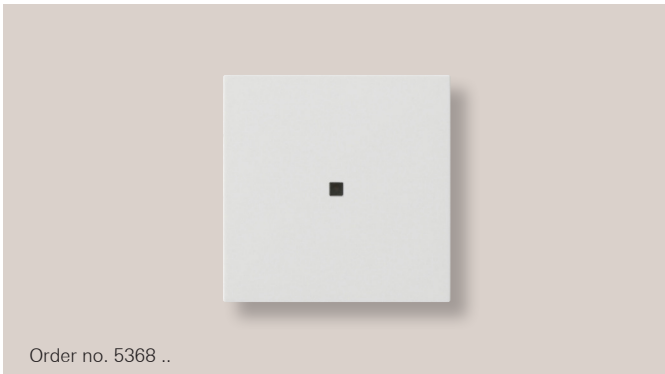

The operating top unit BT is a single-channel top unit for System 3000 inserts. The top unit consists of a rocker with a status LED. The rocker can be operated at the top, bottom and additionally across the entire surface. You can set and program this easily by Bluetooth using your smartphone and the Gira System 3000 App.

Functions at a glance:

- Lighting control and configuration with corresponding inserts
- Shading control and configuration with the corresponding inserts
- Top unit for 3-wire auxiliary insert
- Connected sun protection and twilight function with System 3000 brightness and temperature sensor BT
- 40 switching times, at each switching time blind and slat positions or switching and dimming values can be saved
- Night mode, i.e. the status LEDs are not permanently illuminated
- Operation of the System 3000 inserts via Gira System 3000 App with status feedback in values (0 to 100 per cent, On/Off)
- Switch-on brightness can be saved with dimming insert
- Copying of switching times via Gira System 3000 App to other operating top units BT
- Astro function using GPS data in the Gira System 3000 App for every switching time
- Automatic setting of summer and winter time, and automatic time synchronisation via Gira System 3000 App
- Random function
- Additional parameters can be set depending on the System 3000 insert

System 3000 blind timer and timer BT

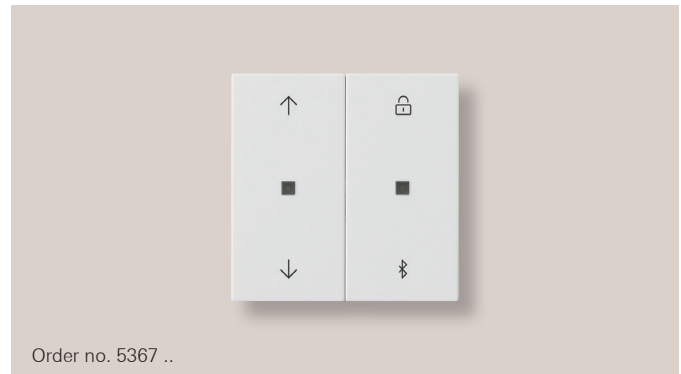

The blind timer and timer BT is a single-channel top unit for System 3000 inserts. The top unit consists of a split rocker that looks like a rocker, 2-gang. The rocker can be operated at the top, bottom and additionally across the entire surface. The colour LED at the right shows the different functions, the colour LED at the left indicates the respective status. You can set and program this easily by Bluetooth using your smartphone and the Gira System 3000 App.

Functions at a glance:

- Lighting control and configuration with corresponding inserts
- Shading control and configuration with the corresponding inserts
- Top unit for 3-wire auxiliary insert
- Connected sun protection and twilight function with System 3000 brightness and temperature sensor BT
- 40 switching times, at each switching time blind and slat positions or switching and dimming values can be saved
- Night mode, i.e. the function and status LED lights are not permanently illuminated
- Blocking function to deactivate automatic functions, auxiliary units and time programs
- Operation of the System 3000 inserts via Gira System 3000 App with status feedback in values (0 to 100 per cent, On/Off)
- Switch-on brightness can be saved with dimming insert
- Copying switching times via Gira System 3000 App to other blind timers and timers BT
- Astro function using GPS data in the Gira System 3000 App for every switching time
- Automatic setting of summer and winter time, and automatic time synchronisation via Gira System 3000 App
- Random function
- Additional parameters can be set depending on the System 3000 insert

eNet wireless operating top unit eNet wireless operating top unit arrow symbols



The eNet wireless operating top unit is a single-channel top unit for integrating System 3000 inserts into the eNet wireless system. The top unit consists of a rocker with a status LED. The rocker can be operated at the top, bottom and additionally across the entire surface. By integrating it into the eNet wireless system, a variety of different functions and settings are possible, especially in connection with an eNet server.

Functions at a glance:

- Lighting control with corresponding inserts
- Shading control with corresponding inserts
- Top unit for 3-wire auxiliary insert
- Status feedback to wireless transmitter
- Evaluation of auxiliary inputs
- Integration into light and blind scenes

With eNet server (depending on insert)

- Repeater function
- Adjustment time when changing directions
- Operation locks
- Deactivate auxiliary unit evaluation
- Position for sun protection, twilight, lock-out protection and wind alarm
- Maximum and minimum brightness
- Dimming speed and dimming ramp up/down
- Switch on/off delay
- Switch-off pre-warning
- Permanently on, permanently off
- Hotel function
- Delay time
- Light control
- Fully encrypted wireless transmission (AES-CCM)

eNet wireless operating top unit Memory eNet wireless operating top unit Memory arrow symbols

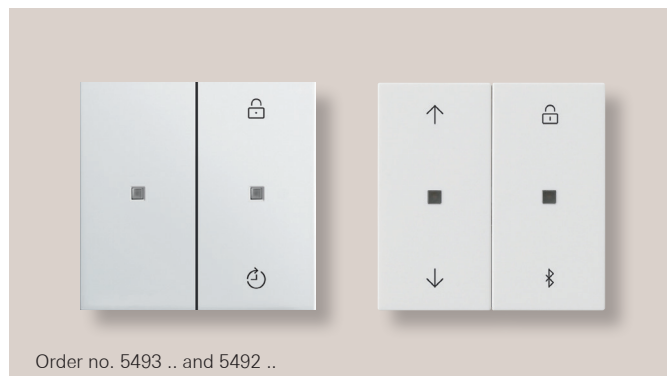

The eNet wireless operating top unit is a single-channel top unit for integrating System 3000 inserts into the eNet wireless system. The top unit consists of a split rocker that looks like a rocker, 2-gang. Each side of the rocker is assigned a colour LED, which serves as a function display, status display and orientation light. The rocker can be operated at the top, bottom and additionally across the entire surface. By integrating it into the eNet wireless system, a variety of different functions and settings are possible, especially in connection with an eNet server.

Functions at a glance:

- Lighting control with corresponding inserts
- Shading control with corresponding inserts
- Top unit for 3-wire auxiliary insert
- Status feedback to wireless transmitter
- Evaluation of auxiliary inputs
- Integration into light and blind scenes
- Night mode, i.e. the function and status LED lights are not permanently illuminated
- Blocking function to deactivate all automatic, auxiliary unit and Memory functions
- Contains a memory function with two switching times that are repeated every 24 hours

With eNet server (depending on insert)

- Repeater function
- Adjustment time when changing directions
- Operation locks
- Deactivate auxiliary unit evaluation
- Position for sun protection, twilight, lock-out protection and wind alarm
- Maximum and minimum brightness
- Dimming speed and dimming ramp up/down
- Switch on/off delay
- Switch-off pre-warning
- Permanently on, permanently off
- Hotel function
- Delay time
- Light control
- Fully encrypted wireless transmission (AES-CCM)

4.2 Switches and buttons

System 3000 provides switching and impulse inserts so that lighting can be switched on and off easily. All Gira inserts are functional without top units. Even setting an operating mode works without a top unit. The relay switching insert is approved for a temperature range of $-25\text{ }^{\circ}\text{C}$ to $+45\text{ }^{\circ}\text{C}$. The inserts are not suitable for safety-relevant applications.

4.2.1 Components

Top units	Order no.
System 3000 operating top unit	5360 ..
System 3000 operating top unit arrow symbols	5361 ..
System 3000 touch top unit	5365 ..
System 3000 operating top unit, 2-gang	5362 ..
System 3000 operating top unit Memory arrow symbols	5363 ..
System 3000 blind timer and timer Display	5366 ..
System 3000 operating top unit BT	5368 ..
System 3000 blind timer and timer BT	5367 ..
eNet wireless operating top unit arrow symbols	5494 ..
eNet wireless operating top unit	5495 ..
eNet wireless operating top unit Memory arrow symbols	5492 ..
eNet wireless operating top unit Memory	5493 ..
System 3000 motion detector top unit 1.10 m Standard	5373 ..
System 3000 motion detector top unit 1.10 m Komfort BT	5374 ..
System 3000 motion detector top unit 2.20 m Standard	5375 ..
System 3000 motion detector top unit 2.20 m Komfort BT	5376 ..
System 3000 presence and motion detector 360° top unit BT	5377 02
Inserts	Order no.
System 3000 relay switching insert	5403 00
System 3000 relay switching insert, 2-gang	5404 00
System 3000 electronic switching insert	5405 00
System 3000 impulse insert	5410 00
Sensor	Order no.
System 3000 brightness and temperature sensor	5466 02

4.2.2 Definitions

Switch

An electrical installation device with an operating element that is operated by pressing, turning or tilting. The electrical contact is closed by an actuation and remains closed until the operating element is actuated a second time.

An example of this is the operation of a light switch. If the switch is pressed, the living room light switches on and stays on. If the light switch is pressed a second time, the living room light switches off again.

Button

An electrical installation device with an operating element that is operated by pressing and then returns to its initial position. The electrical contact is closed only for the duration of the operation. An example of this is the operation of a door bell button. As long as the door bell button is pressed, the door bell will sound. As soon as the door bell button is released, the door bell will no longer sound.

Delay time

The relay switching insert and electronic switching insert work as switches. That is, they switch on the lights when first actuated and off when actuated again. You have the option of setting a delay time for the relay switching insert. After the delay time has elapsed, the relay switching insert automatically switches the lighting off again. Within this delay time, you can also manually switch off the load on the operating top unit.

You can set the delay times for the relay switching insert as follows:

- Switch (no delay time)
- 1 minute
- 5 minutes
- 30 minutes
- 60 minutes

The delay time function is first and foremost an energy-saving function: In particular in rooms where someone is not permanently present (e.g. office kitchens), the light is automatically switched off after a certain period of time. This function can also be used so that when leaving the house, for example, the light in the hallway stays on to give the impression that there is still someone at home.

An extension of the delay time by repeated pressing is not possible.

4.2.3 Switch as main and auxiliary units

The relay switching insert and the electronic switching insert become a light switch with the operating top unit.

The impulse insert can be operated manually with the operating top unit. In combination with a motion detector top unit, this becomes a staircase light circuit. When it is dark, it automatically switches the lighting on and off with each detected movement in conjunction with the staircase light timer.

The relay switch insert, 2-gang can switch two independent outputs with an operating top unit, 2-gang. With an operating top unit or a motion detector top unit, for example, the second output can switch as a function of the first output. The second output switches a ventilation system on depending on the lighting, for example, and switches it off again with a delay.

System 3000 main units

The main unit consists of one device insert and one matching operating top unit.

Any number of not-illuminated buttons and 2-wire auxiliary inserts can be connected to auxiliary unit terminal 1 of the main unit.

System 3000 auxiliary units

The auxiliary unit consists of one auxiliary insert with a matching top unit or rocker button.

A System 3000 main unit can be controlled by System 3000 auxiliary units by placing a signal on Terminal 1 of the main unit insert when activated.

The functionality that results on the main unit depends on the choice of device. The following devices can be used as an auxiliary unit:

- A 230 V (rocker) button as NO contact
- A 2-wire auxiliary insert with operating top unit
- A 3-wire auxiliary insert with any System 3000 top unit

4.2.4 Mounting and settings

The Gira relay switching inserts and impulse inserts already offer functions to automate lighting. This section gives an overview of the installation steps and the adjustable operating modes and functions.

Relay switching insert

Connecting and installing the insert

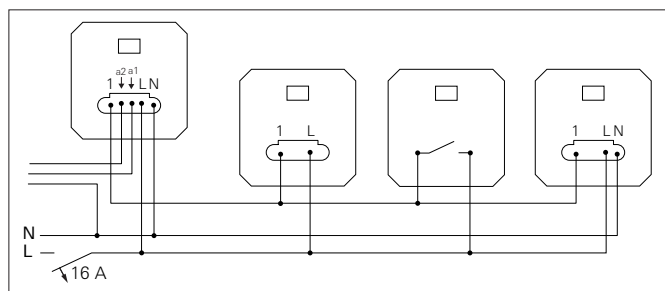

Observe the following during installation:

- Illuminated buttons must have a separate N terminal.
- Do not plug in the top unit while powered on, and do not change it while powered on, as this may cause a malfunction.

To set the delay time, proceed as follows:

1. Press the TEST button for more than four seconds. After pressing the TEST button, the LED lights up in the colour of the set delay time.
2. Briefly release the TEST button and then press the button repeatedly until it lights up in the colour of the desired delay time.

LED colour	Pre-defined delay time
Green	Switching without delay time
White	Delay time: 1 minute
Blue	Delay time: 5 minutes
Yellow	Delay time: 30 minutes
Red	Delay time: 60 minutes

3. The selected delay time is automatically saved after 30 seconds. If the LED goes out, the saving process was successful.

Relay switching insert, 2-gang

Connecting and installing the insert

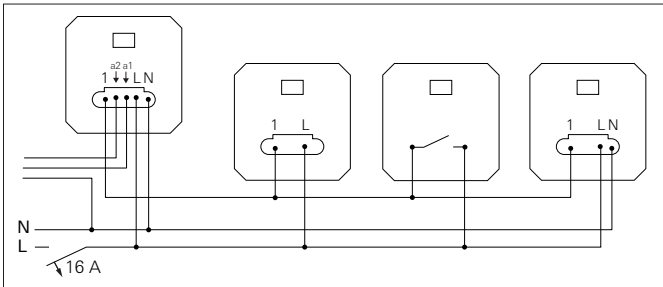

Observe the following during installation:

- Illuminated buttons must have a separate N terminal available.
- Do not plug in the top unit while powered on, and do not change it while powered on, as this may cause a malfunction.
- Only use these 16 A circuit breakers

Manufacturer	Type
Schneider Electric	A9F03116
ABB	S201-B16
ABL Sursum	B16S1
Hager	MBN116
Legrand	403357
Siemens	5SL61166

Setting the time function/delay time for output a2

To set the time function/delay time for output a2, follow the same procedure as for setting the delay time for the relay switching insert. The LED colours and delay times are identical.

Activating switch-on delay for output a2

A switch-on delay of 3 minutes can be activated for output a2. This starts as soon as output a1 is switched on. If output a1 is switched off again before the switch-on delay has elapsed, output a2 remains switched off.

Requirements:

Both outputs are switched off.

1. Press the entire surface of the pushbutton top unit for more than 4 seconds.
Both outputs switch on immediately. After 4 seconds, output a2 switches off.
2. Release pushbutton top unit.
Switch-on delay is activated.

Deactivating switch-on delay for output a2

Requirements:

Both outputs are switched off.

1. Press the entire surface of the pushbutton top unit for more than 4 seconds.
Output a1 switches on immediately. Output a2 also switches on after 4 seconds.
2. Release pushbutton top unit.
Switch-on delay is deactivated. Both outputs are activated simultaneously.

Electronic switching insert

Connecting and installing the insert

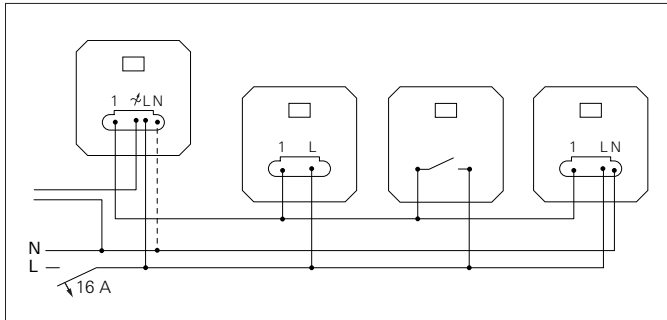

Observe the following during installation:

- If non-dimmable LED lights are used, the neutral conductor must be connected. If other light sources are used, operation without a neutral conductor is possible.
- A maximum of 600 W LED or compact fluorescent lamps can be connected per 16 A circuit breaker.

Setting the operating mode

In the event of operation without a neutral conductor, the operating mode must match the load. The operating mode is usually set automatically. However, it may be necessary to set the operating mode manually.

In the event of operation with a neutral conductor, the operating mode can not be set. The status LED has no function in this case.

You can set the following operating modes:

Universal, R, L, C, LED

- Factory preset
- Automatic measurement on the load, the trailing edge, leading edge or LED leading edge
- Load type:
 - Light bulbs
 - HV halogen lamps
 - Dimmable HV LED lights or compact fluorescent lamps
 - Dimmable electronic or inductive transformers for halogen and LED lights

LED trailing edge

- Connection of inductive transformers not permitted
- Load type:
 - Light bulbs
 - HV halogen lamps
 - Trailing-edge dimmable HV LED and compact fluorescent lamps
 - Trailing-edge dimmable electronic transformers for halogen and LED lights

LED leading edge

- Connection of inductive transformers not permitted
- Load type:
 - Light bulbs
 - HV halogen lamps
 - Leading-edge dimmable HV LED and compact fluorescent lamps
 - Leading-edge dimmable electronic transformers for halogen and LED lights

4.3 Dimming

To set the operating mode, proceed as follows:

1. Make sure the load is switched off.
2. Press the TEST button for more than four seconds until the LED lights up.
3. Press the TEST button within one second until the required operating mode is selected.

LED colour	Operating mode
Green	R, L, C, LED
Red	LED trailing edge
Blue	LED leading edge

The LED lights up in the colour of the selected operating mode.

4. Within the next 30 seconds, press the TEST button for more than one second.

The LED switches off and the light switches on. The operating mode is saved. If the TEST button is not pressed within 30 seconds for longer than one second, the operating mode will not be saved and the LED goes out.

Impulse insert

The impulse insert is used exclusively for setting up staircase lighting controls. The impulse insert supplies control signals to a DRA staircase light timer, which centrally switches the staircase lighting.

You can install one or more impulse inserts on each floor of a staircase. Either operating top units or motion detector top units are mounted on the impulse inserts. A switch-on signal is sent to the staircase light timer either by manual actuation of the operating top unit or by the detection of movement.

The staircase lighting is switched on for the set delay time.

Retriggering of the delay time by repeatedly pressing the operating top unit or by repeated detection by the motion detector is made possible by the impulse insert. Retriggering resets the delay time to the start time and extends the lighting duration of the staircase lighting.

Basically, a lighting system is initially designed for the maximum brightness required. In practice, however, many situations require the lighting to be lowered and to adapt to individual needs.

Dimmed light improves lighting and living quality, creates individual lighting conditions for everyday work, and makes a significant contribution to energy savings.

4.3.1 Components

Top units	Order no.
System 3000 operating top unit	5360 ..
System 3000 operating top unit arrow symbols	5361 ..
System 3000 touch top unit	5365 ..
System 3000 operating top unit, 2-gang	5362 ..
System 3000 operating top unit Memory arrow symbols	5363 ..
System 3000 blind timer and timer Display	5366 ..
System 3000 operating top unit BT	5368 ..
System 3000 blind timer and timer BT	5367 ..
eNet wireless operating top unit arrow symbols	5494 ..
eNet wireless operating top unit	5495 ..
eNet wireless operating top unit Memory arrow symbols	5492 ..
eNet wireless operating top unit Memory	5493 ..
System 3000 motion detector top unit 1.10 m Standard	5373 ..
System 3000 motion detector top unit 1.10 m Komfort BT	5374 ..
System 3000 motion detector top unit 2.20 m Standard	5375 ..
System 3000 motion detector top unit 2.20 m Komfort BT	5376 ..
System 3000 presence and motion detector 360° top unit BT	5377 02
Inserts	Order no.
System 3000 universal LED dimming insert Standard	5400 00
System 3000 universal LED dimming insert Komfort	5401 00
System 3000 universal LED dimming insert Komfort, 2-gang	5402 00
System 3000 DALI Power control unit, flush-mounted insert	5406 00
System 3000 universal LED rotary dimming insert Standard	2450 00
System 3000 universal LED rotary dimming insert Komfort	2455 00
System 3000 universal LED dimmer Mini	2440 00
System 3000 universal LED dimmer DRA	2365 00
System 3000 universal LED power booster DRA	2383 00
Sensor	Order no.
System 3000 brightness and temperature sensor BT	5466 02

4.3.2 Mounting and settings

Connecting and installing the DRA dimmer

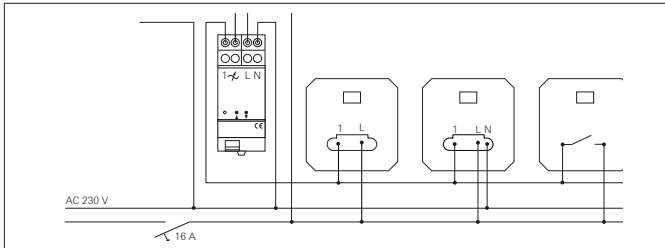

DRA dimmer and universal LED power booster DRA – Connecting and installing

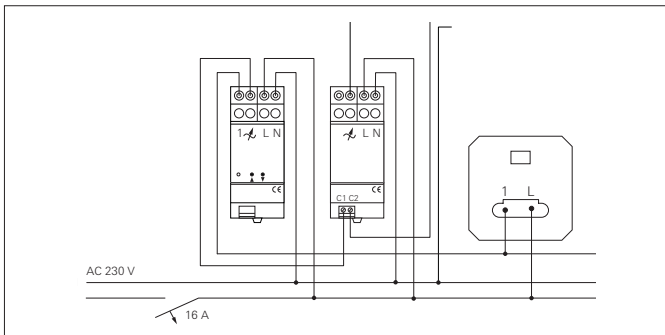

Observe the following during installation:

- When operating multiple dimmers or power boosters in a sub-distribution between the DRA devices, a distance of 1 MW (about 18 mm) should be kept to avoid overheating.
- A maximum of 600 W LED or compact fluorescent lamps can be connected per 16 A circuit breaker.
- When connecting electronic transformers, pay attention to the specifications of the transformer manufacturer.
- When using several power boosters, add up the minimum load of the individual power boosters.
- Only connect illuminated buttons if they have a separate N terminal.

Setting the operating mode

The operating mode must match the load. The operating mode is usually set automatically. However, it may be necessary to set the operating mode manually.

You can set the following operating modes:

Universal, R, L, C, LED

- Factory preset
- Automatic measurement on the load, the trailing edge, leading edge
- Load type:
 - Light bulbs
 - HV halogen lamps

- Dimmable HV LED lights or compact fluorescent lamps
- Dimmable electronic or inductive transformers for halogen and LED lights

LED trailing edge

- Connection of inductive transformers not permitted
- Load type:
 - Light bulbs
 - HV halogen lamps
 - Trailing-edge dimmable HV LED and compact fluorescent lamps
 - Trailing-edge dimmable electronic transformers for halogen and LED lights

LED leading edge

- Connection of inductive transformers not permitted
- Load type:
 - Light bulbs
 - HV halogen lamps
 - Leading-edge dimmable HV LED and compact fluorescent lamps
 - Leading-edge dimmable electronic transformers for halogen and LED lights

To set the operating mode, proceed as follows:

1. Make sure the load is switched off.
2. Press both buttons at the same time for more than four seconds until the LED lights up.
3. Press one of the two buttons for less than one second, as often as needed until the required operating mode is selected.

LED colour	Operating mode
Green	R, L, C, LED
Red	LED trailing edge
Blue	LED leading edge

The LED lights up in the colour of the selected operating mode.

4. Press and hold both buttons.
 - LED flashes in the colour of the selected operating mode.
 - Light switches on at the lowest brightness level and slowly brightens.
5. Once the desired minimum brightness has been reached, release both buttons.

The LED lights up in the colour of the selected operating mode and the light is switched on. The operating mode is saved. If neither of the buttons is pressed within 30 seconds, the operating mode is saved and the LED lights up green.

Connecting and mounting the universal LED dimming insert Komfort, 2-gang

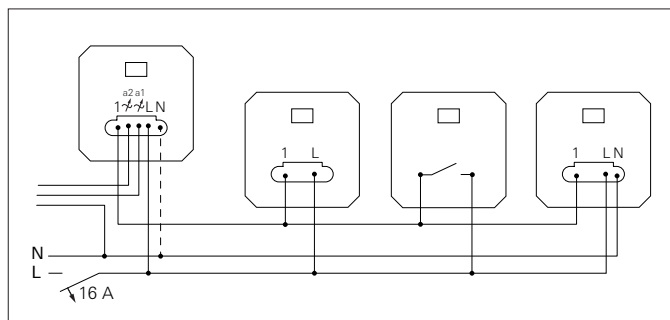

Observe the following during installation:

- A maximum of 600 W LED or compact fluorescent lamps can be connected per 16 A circuit breaker.
- When connecting electronic transformers, pay attention to the specifications of the transformer manufacturer.
- Only connect illuminated buttons if they have a separate N terminal.
- Output a1 must be ready for operation, otherwise the dimmer will not function.

Operation

- Operating top unit, 2-gang: Left: Switching of output a1.
Right: Switching of output a2.
- Operating top unit: Both outputs a1 + a2 are switched together.

Setting the operating mode

To set the operating mode, proceed as follows:

The operating mode and minimum brightness can be set individually for each output.

1. Press the dimming mode button for more than 4 seconds until both LEDs light up.
2. Press the dimming mode button briefly and repeatedly until the required operating mode is selected for an output.
One of the two LEDs lights up in the colour of the selected operating mode

LED colour	Operating mode
Green	R, L, C, LED
Red	LED trailing edge
Blue	LED leading edge

3. Press and hold the dimming mode button for more than 1 second.
The corresponding LED flashes. Light switches on at the lowest brightness level and slowly becomes brighter.
4. Once the desired minimum brightness has been reached, release the dimming mode button.
The corresponding LED lights up, operating mode and minimum brightness are set.
5. Change the minimum brightness level again:
Press the dimming mode button for more than 1 second.

6. Saving settings: Press the dimming mode button for less than 1 second or do not press it for 30 seconds.
The corresponding LED goes out.

Auxiliary units

Operation with 3-wire auxiliary insert and operating top unit, 2-gang is essentially the same as operation at the main unit. 3-wire auxiliary insert with simple operating top unit and 3-wire rotary auxiliary insert operate output a1 only. 2-wire auxiliary insert with operating top unit or button operate both outputs together.

4.3.3 Dimmability of light sources

Light bulbs

The light bulb is a 'thermal radiator'. In the light bulb, a current flows through a thin filament made of conductive material, the spiral-wound filament. The spiral-wound filament is heated until it lights up yellow or white.

Halogen bulbs

One special design of the light bulb is the halogen bulb. These are available in the following variants: high voltage (HV) for mains voltage and low voltage (LV) for low voltage.

High-voltage halogen bulbs are relatively easy to dim. Using an edge dimmer (leading edge or trailing edge), part of the sinusoidal mains voltage is cut off in each half-wave, thereby supplying the bulb with a lower effective voltage. This creates gaps in the power supply of a few milliseconds, which, however, have no appreciable effect due to the thermal inertia of the filament.

High-voltage halogen bulbs can theoretically be dimmed without any restrictions. When dimming, high-voltage halogen bulbs change their colour temperature to warmer (lower) values and the life of the light source usually increases significantly. Even the low-voltage halogen bulbs are dimmable using the same principle. Here, however, the fact that the ballast (electronic transformer), which generates the required low voltage, can also be dimmed must be taken into account. Details on compatibility can be found in the transformer manufacturer's product documentation.

LED lights

Not least due to the EU-wide ban on incandescent light bulbs in the context of the German Energy Saving Ordinance, LED lights have gained popularity in recent years. The actual light sources in LED lights are light-emitting diodes that consist of semiconductor materials. LED lights require considerably less energy than the classic light bulb.

In addition, LED lights last significantly longer: If one assumes that light bulbs have about 1,000 operating hours, the manufacturers of LED lights typically indicate a service life of 20,000 to 50,000 operating hours.

Unlike light bulbs, LED lights are a very fast light source, and begin to glow immediately upon the onset of current flow without producing any subsequent glow when the power is switched off.

Even LED lights can be dimmed. While halogen lights and light bulbs are operated with alternating current, LED lights require direct current. LEDs are also operated with operating voltages below 1 V. Therefore, LED lights require a ballast – either as a separate device or integrated into the lamp.

The tasks of the ballast are, on the one hand, to lower the mains voltage to LED-compatible levels, and, on the other hand, to supply continuous power to the LED during supply gaps, which inevitably arise in leading and trailing edge phases. In addition, if necessary, the dimming process is controlled via the ballast (PWM, for dimmable LED lights) and the colour temperature is adjusted.

Dimmable LED lights must be expressly marked as “dimmable” in order to operate on leading or trailing edge.

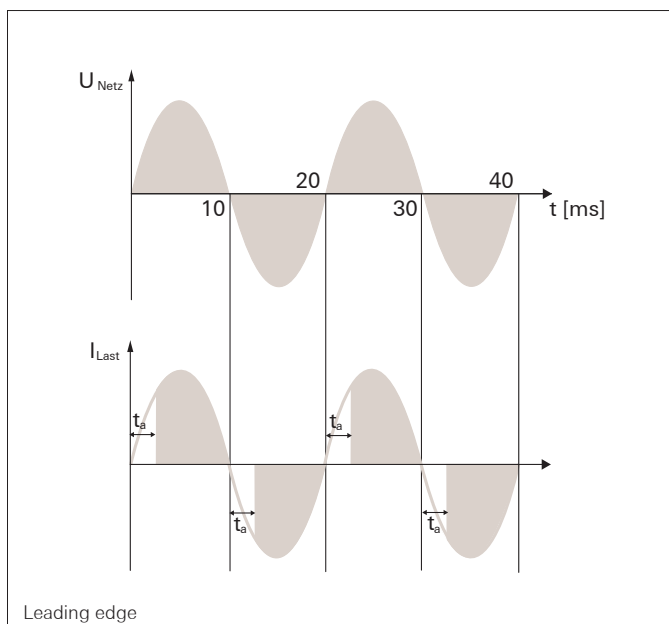

4.3.4 Dimming principles

Leading edge

With the leading edge principle, the dimmer blocks the flow of current to the light at the beginning of each half sine wave. It is insulating. Only after expiry of an adjustable delay time is the electronic switch in the dimmer switched on and the connected lights receive power. With the next sine zero, the current flow is extinguished and the lamp is switched off. This process is repeated for every sine wave, i.e. 100 times per second. The brightness of the connected light sources can be infinitely adjusted via the delay time.

The leading edge principle is suitable for ohmic and inductive loads, light bulbs or low-voltage halogen bulbs with a conventional (wound) transformer. In addition, there are LED lights that are specially approved for dimming according to the approved, leading-edge principle.

Trailing edge

With the trailing edge principle, the lights are switched on in the sine half-wave zero crossing and are switched off again after an adjustable delay time. The advantage here is that no interference voltages occur when switching on, because the voltage at the time is equal to zero.

The trailing edge principle is suitable for all light bulbs and loads with a capacitive input behaviour, e.g. electronic transformers.

There are also LED lights that are only suitable for the trailing edge principle. These are, for example, lamps that have a capacitor on the input side (for example, for radio interference suppression). When it is discharged, it acts as a short-circuit for a short time when it is switched on. This effect would produce high current peaks in the leading edge due to the steep switch-on edges.

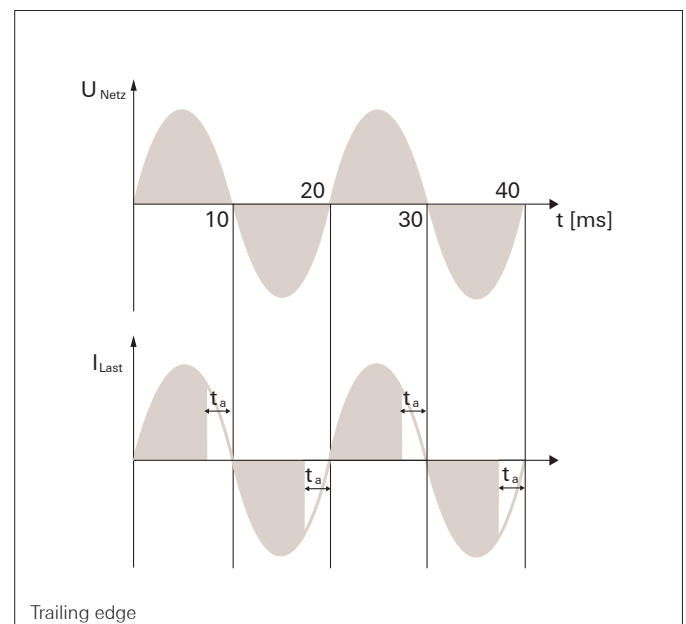

4.3.5 Installation-related power reduction

In addition to the basic compatibility of the light sources and possibly the ballasts, the planned installation position must be taken into account.

Since dimmers have a higher power loss than relays, special attention must be paid to the heat generated by the power loss. To avoid damage, the resulting heat must be safely diverted. The heat is usually diverted through the mounting plate into the wall. If this is not possible, for example because the dimmer is installed in a surface-mounted device box or in a cavity wall box in a plasterboard framework, the rated load must be reduced.

Rules and examples on how to reduce the rated load

In the event of higher ambient temperature
Reduction by 10 per cent for every 5 °C above the ambient temperature above 25 °C
<p>Example: Installation of a 500 W dimmer in an ambient temperature of 40 °C</p> $40\text{ °C} - 25\text{ °C} = 15\text{ °C}$ $15\text{ °C} / 5\text{ °C} = 3$ $3 \times 10\text{ per cent} = 30\text{ per cent}$ <p>Result: Reduction of the rated load by 30 per cent</p>
The 500 W dimmer may only be charged with 70 per cent of the specified rated output, i.e. with 350 W.

For installation in cavity walls, plasterboard or wooden walls, for installation in furniture
Reduction by 15 per cent
<p>Example: Installation of a 500 W dimmer in a wall unit</p> <p>Result: Reduction of the rated load by 15 per cent</p>
The 500 W dimmer may only be charged with 85 per cent of the specified rated output, i.e. with 425 W.

When installing multiple dimmers above or next to each other
Reduction for the external devices by 10 per cent, for the internal devices by 20 per cent
<p>Example: Installation of three 500 W dimmers side by side in a multiple combination</p> <p>Result: Reduction of the rated load by 10 and 20 per cent</p>
<p>The two outer 500 W dimmers may only be charged with 90 per cent of the specified rated output, i.e. with 450 W.</p> <p>The inner 500 W dimmer may only be charged with 80 per cent of the specified rated output, i.e. with 400 W.</p>

If several of these conditions are met in an installation, the rated output must be reduced accordingly even further.

4.3.6 Setting the operating mode and basic brightness

All Gira System 3000 dimmers automatically measure the characteristics of the connected load and then choose the most suitable dimming principle. For capacitive and ohmic loads, trailing edge is usually set; for inductive loads, the leading edge is set.

The dimming principle and the basic brightness can also be set manually during start-up using the operating mode selection button. An LED in use indicates the current selection.

LED lights up green

- Automatic load calibration
- Trailing edge for light bulbs, HV halogen bulbs, dimmable HV LED and compact fluorescent lamps as well as dimmable electronic transformers with LV halogen or LV LED lights
- Leading edge for dimmable inductive transformers with halogen or dimmable LED lights
- LED leading edge for dimmable HV LED and compact fluorescent lamps

LED lights up red

- Dimmer operates according to the trailing edge principle
- Setting for light bulbs, HV halogen lamps, dimmable HV LED and compact fluorescent lamps that can be dimmed according to the trailing edge principle
- Dimmable electronic transformers with halogen or LED lights

LED lights up blue

- Dimmer operates according to the leading edge principle
- Setting for light bulbs, HV halogen lamps, dimmable HV LED and compact fluorescent lamps that can be dimmed according to the leading edge principle
- Dimmable electronic transformers with halogen or LED lights

To set the operating mode and the basic brightness, proceed as follows:

First make sure the load is switched off.

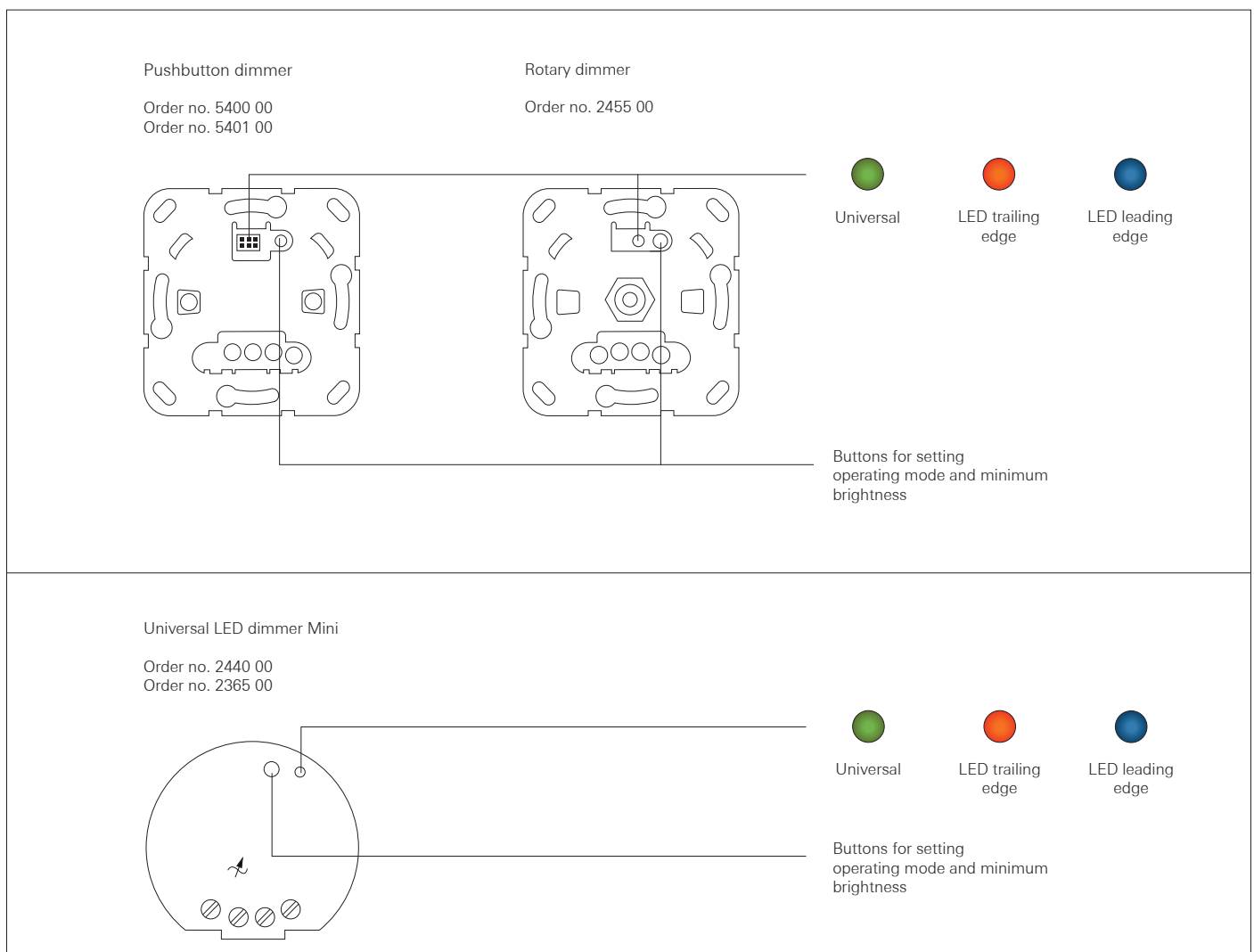

Pushbutton dimmer

Order no. 5400 00
Order no. 5401 00

Rotary dimmer

Order no. 2455 00

Universal LED dimmer Mini

Order no. 2440 00
Order no. 2365 00

1. Buttons for setting the operating mode and minimum brightness

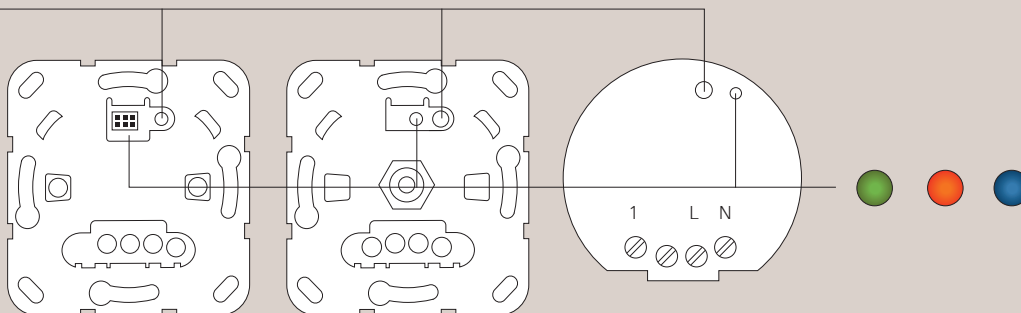

2. Select the operating mode

Press and hold the button, until the LED lights up

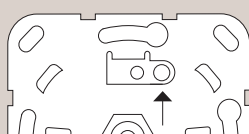

> 4 s



The LED lights up.

3. Press the button briefly and repeatedly until the desired operating mode is selected

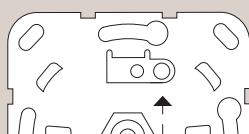

< 1 s



The LED lights up in the colour of the selected operating mode.

> 30 sec timeout Cancel/Reset

4. Set the minimum brightness

Press and hold down the button

When the Automatic operating mode is selected, the first step is to measure the load.

Keep the button pressed.
In the lowest dimming position, the light must light up.

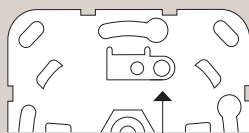

The LED flashes.
The light switches on at the lowest brightness level and slowly brightens.

Once the desired minimum brightness has been reached, release the button

Change the minimum brightness level again:
The light switches back to the lowest Brightness level and slowly brightens.

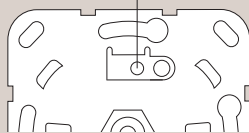

The LED lights up.
Operating mode and minimum brightness are set.

> 30 s timeout
The settings will be saved.

5. Save the setting:
Press the button briefly

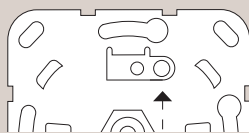

LED goes out

4.3.7 DALI

DALI stands for "Digital Addressable Lighting Interface" and is a standard for digital data transmission between components of a lighting system. DALI was developed in the early 21st century and has largely replaced 1–10 V technology in buildings. The goal was to create an easy-to-use interface in a system with low component costs.

DALI was originally included as Annex E4 of DIN EN 60929 in the international standardisation. As part of the further development and implementation of advanced functions, DALI is currently described in the DIN EN 62386 series of standards.

DALI offers the following functions and options:

- Switching and dimming from different points
- Operating devices of different types and manufacturers have the same dimming behaviour
- Standardised dimming characteristics for adaptation to eye sensitivities
- Selection between linear and logarithmic dimming behaviour
- Switching operation is transferred in the electronic ballast (EVG) (no more wear in the relay, no dimensioning of switching currents necessary, no separate contactors)
- Scene control
- Targeted start-up or initiation of values
- Coordinated fading between scenes
- Individual, group or central control
- White point adjustable during operation (Tunable White, TW)
- Colour control

DALI is particularly suitable for multi-purpose rooms, office rooms and open-plan offices, training and presentation rooms, and production halls.

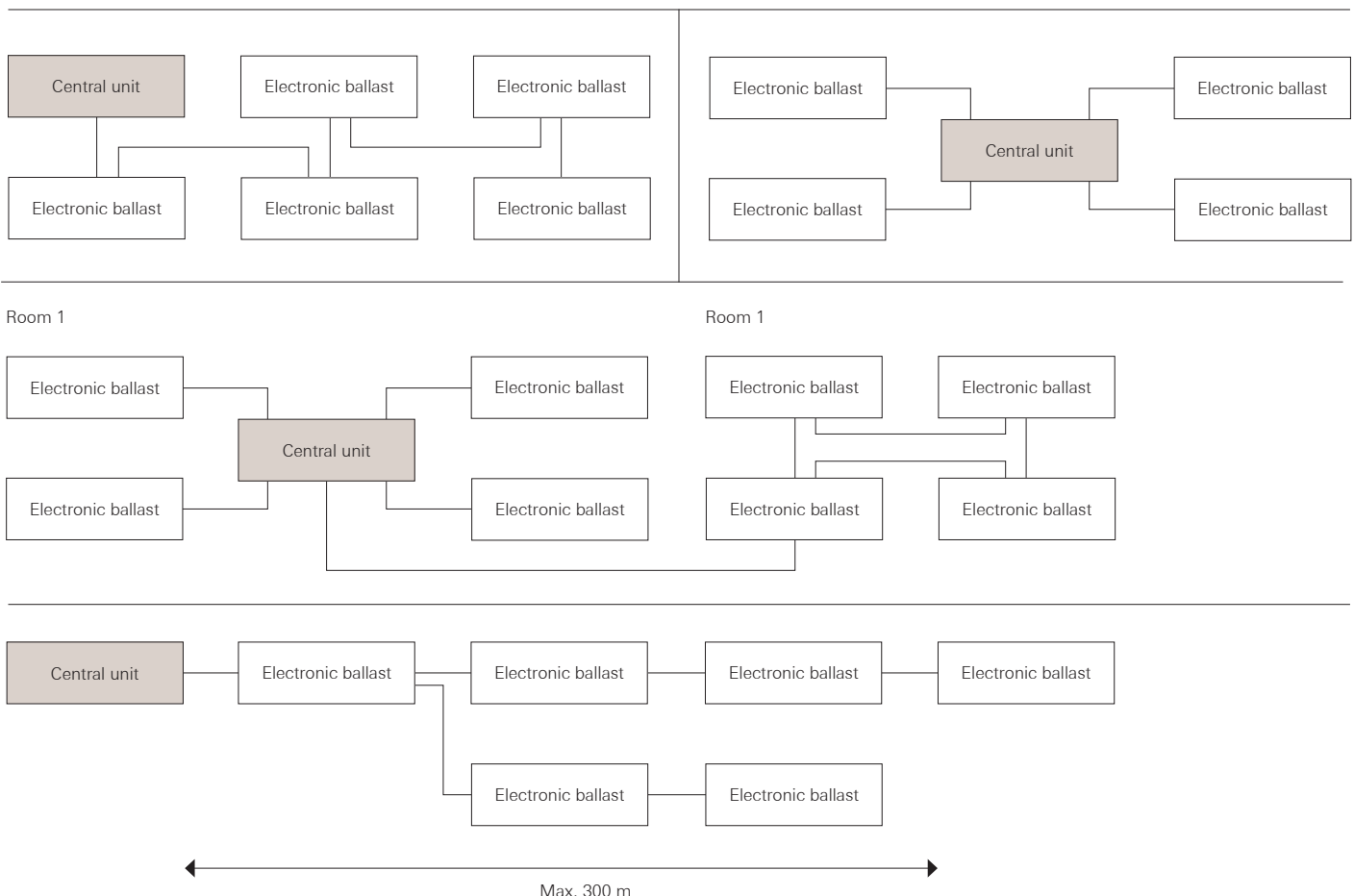

DALI installation rules

When installing a DALI system, note the following:

1. DALI is FELV (functional(ly) extra low voltage).
2. No special data lines need to be used.
An NYM line can be used for example.
3. The same installation rules apply to the cable routing of the DALI control lines as do to mains power systems.
4. DALI control lines and mains voltage lines may be under the same protective sheath or pulled into the same tube.
5. For a 5-wire cable, protective and neutral conductors must be installed.
6. The connected devices may be connected during any phase.
7. DALI devices can be wired as serial or star wiring or as mixed connection.
No terminating resistance is required.
8. The cable length between the control device and the furthest device must not exceed 300 metres.

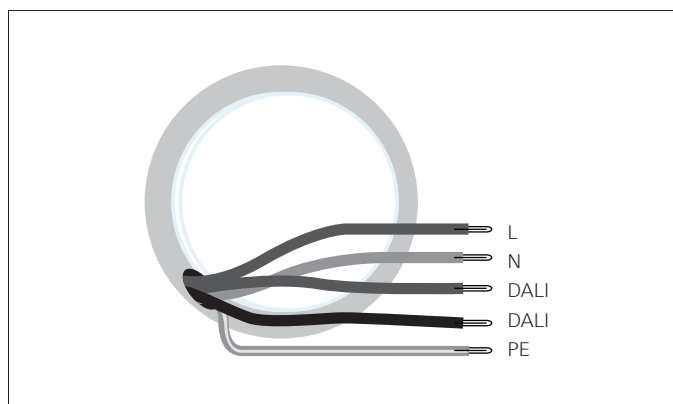

4.3.8 Tips for planning LED light dimmers

Select lights

Make sure the LED lights are dimmable.
If possible, only install lamps from the same manufacturer and from the same batch (same date of manufacture) into a system.

Consider the installation position

Plan to reduce the maximum rated power of the dimmers, depending on the intended installation position and the expected ambient temperature.

Setting the operating mode

First, set the operating mode to “Universal” and test the system.
If problems arise:
Set and check the LED trailing edge operating mode.
If more problems arise:
Set and check the LED leading edge operating mode.

For maximum connected load: Select LED trailing edge.
For the widest possible dimming range: Select LED leading edge.

For complex systems

You can dim larger (LED) loads using power boosters (DRA). Check whether a DALI system is a sensible alternative.

4.3.9 Troubleshooting

Problem	Cause	Remedy
Connected LED or compact fluorescent lamps switch off in the lowest dimming position or flicker.	The basic brightness level set is too low.	Increase the basic brightness level.
Connected lights do not switch on at the lowest dimming setting or are delayed.	The basic brightness level set is too low.	Increase the basic brightness level.
Connected LED or compact fluorescent lamps flicker or buzz; no correct dimming is possible, dimmer buzzes.	Lamps are not dimmable.	Check manufacturer information. Swap lamps out for another type.
	Operating mode (dimming principle) and lamps are not an optimal match.	Check operation in another operating mode; reduce any connected load. Set operating mode manually. Swap lamps out for another type. Use the compensation module LED.
	Dimmer is connected without a neutral conductor.	If possible, connect the neutral conductor, otherwise replace the lamp with another type.
Connected LED or compact fluorescent lamps are too bright in the lowest dimming position; Dimming range is too small.	The basic brightness level set is too high.	Reduce the basic brightness.
	Operating mode (dimming principle) is not an optimal match with the connected HV LED lamps.	Check operation in another operating mode; reduce the connected load if necessary. Set operating mode manually. Swap HV LED lamps out for another type.
Dimmer switches load off briefly and back on again.	Short-circuit protection has been triggered, in the meantime there is no longer an error.	Check the system.

Problem	Cause	Remedy
Dimmer has switched off and cannot be switched on again.	Excess-temperature protection triggered.	<p>Disconnect the dimmer and switch off circuit breakers.</p> <p>LED trailing edge: Reduce the connected load; swap lamps out for another type.</p> <p>LED leading edge: Reduce the connected load; check operation in LED trailing edge setting; swap lamps for another type.</p> <p>Leave the dimmer to cool for at least 15 minutes.</p> <p>Switch circuit breakers and dimmers on again.</p>
	Overvoltage protection has been triggered.	<p>LED trailing edge: Check operation in the LED leading edge setting; reduce the connected load if necessary.</p> <p>Swap lamps out for another type.</p>
	Short-circuit protection triggered.	<p>Disconnect the dimmer and switch off circuit breakers.</p> <p>Repair short circuit.</p> <p>Switch circuit breakers and dimmers on again.</p> <p>Note: The short-circuit protection is based on an electronic fuse; the load circuit is not galvanically isolated from the mains supply when switched off.</p>
	Load failure	<p>Check load.</p> <p>Replace light source.</p> <p>For inductive transformers: Check primary fuse.</p>
	Dimmer is connected without a neutral conductor.	<p>If possible, connect the neutral conductor, otherwise replace the lamp with another type.</p>
LED light shines dimly when dimmer is switched off ("ghosting effect").	LED light is not suitable for this dimmer.	<p>Use another type of LED light or one from another manufacturer.</p> <p>Connect the neutral conductor to the dimmer.</p> <p>Use the compensation module LED.</p>

4.4 Automatic lighting

For more safety and greater convenience, System 3000 offers components for automatic, motion-dependent lighting control. The motion detectors, security lights and presence detectors from Gira automatically switch on the lighting if movement is detected in the detection field and switch off again after a set delay time has elapsed – all in a convenient and energy-saving manner.

Basically, the motion-dependent lighting control can be divided into two typical fields of application:

Motion detector

Motion detectors that are particularly suitable for transit areas such as stairs and hallways. The task of the motion detector is to switch on the light as a function of the ambient brightness when a person enters the detection range and to switch off the light when the person leaves the room again. The main focus here is on avoiding dangerous situations in the dark. In this application, it is not necessary to switch off the light manually. In this case, the desired delay time always elapses and the light switches off if the delay time is not reactivated by new motion.

Presence detector

Presence detectors are motion detectors that are typically placed in rooms where people are present for longer periods. The presence detector has the primary objective of saving energy and switching off or dimming the room lighting if no-one is present. For this, the presence detector must be able to detect even small and sporadic movements. In this application, the light must also be able to be switched off manually. Presence detectors can be switched off if necessary and movements ignored in the detection range.

In addition, all System 3000 motion detectors and presence detectors measure the ambient brightness and thus make the control of automatic lighting even more intelligent: You can set the lighting to only be switched on during movement if an additional brightness threshold is not reached. Or you can design more complex systems in which further motion detectors or presence detectors are activated when a motion detector is triggered.

The Gira presence and motion detector 360° top unit BT can be used as a motion detector and as a presence detector.

4.4.1 Components

Top units	Order no.
System 3000 motion detector top unit 1.10 m Standard	5373 ..
System 3000 motion detector top unit 1.10 m Komfort BT	5374 ..
System 3000 motion detector top unit 2.20 m Standard	5375 ..
System 3000 motion detector top unit 2.20 m Komfort BT	5376 ..
System 3000 presence and motion detector 360° top unit BT	5377 02

Inserts	Order no.
System 3000 relay switching insert	5403 00
System 3000 relay switching insert, 2-gang	5404 00
System 3000 electronic switching insert	5405 00
System 3000 universal LED dimming insert Standard	5400 00
System 3000 universal LED dimming insert Komfort	5401 00
System 3000 universal LED dimming insert Komfort, 2-gang	5402 00
System 3000 3-wire auxiliary insert	5409 00
System 3000 DALI Power control unit, flush-mounted insert	5406 00
System 3000 impulse insert	5410 00

4.4.2 Operation and functions

The motion detectors and presence detectors from Gira offer a wide range of functions to automate the lighting conveniently and on demand. This section gives an overview of the individual operating modes and functions.

Motion detector operating mode

In motion detector mode, automatic load switching occurs as a function of thermal motion and ambient brightness. The lighting can not be switched off via an operating point (switch, button or wireless network).

Area of application

Entrance and transit areas (corridors and stairs), garages, cellars, bathrooms and guest WCs.

Presence detector operating mode

In presence detector mode, automatic load switching occurs as a function of thermal motion and ambient brightness. In presence detector mode, the lighting can be switched off via an operating point (2-wire auxiliary unit, 3-wire auxiliary unit, button or wireless network). Restarting during an active motion detection during the delay time is deactivated.

In conjunction with the dimming inserts, you can adjust the lighting to an individually-set brightness depending on motion. In this combination, the presence detector continuously measures the amount of artificial light and daylight. If the determined switching threshold is not reached, the presence detector switches on the light when motion is detected and adjusts it so that the desired brightness value is reached. The brightness in the room thus remains constant, regardless of the amount of daylight entering the room. This is called "constant light control".

Area of application

Offices, conference rooms, WCs, sports halls, warehouses. In connection with dimming inserts, especially offices, conference rooms and production areas.

The presence mode is activated and set easily and conveniently via smartphone and the Gira System 3000 App.

The following parameters can be programmed:

- Detection range
- Sensitivity of all sensors
- Brightness threshold
- Fixed or dynamic delay time
- Switch-off pre-warning
- Presence simulation
- Hotel/orientation light function
- Night light function
- Constant light control
- Alarm mode
- Walking test
- Presence simulation
- Day mode

Function: Permanent On

The load is switched on manually until the function is deactivated again. With the Gira System 3000 App or a switch on the device, you can use this function to prevent the presence detector from detecting presence and from switching off the lighting during periods of low activity.

A typical application scenario is, for example, preventing the light from switching off when doing homework or reading in the bathtub, or in staircases when moving furniture.

Function: Permanent Off

The load is switched off manually until the function is deactivated again. Using the Gira System 3000 App or a switch on the device, this function prevents the lighting from being switched on, even if the device detects the presence of a person.

A typical application scenario is the prevention of light switching on when motion is detected, e.g. during film screenings or projector presentations.

Function: 0.5 – 5 hours Permanent On

The load is permanently switched on for a period of 0.5 to 5 hours (or until manual deactivation).

In principle, this function behaves like the "Permanent On" function, except that it is automatically deactivated after a set time and switches to automatic mode ("AUTO" function). Manual deactivation is therefore not actually necessary.

Function: 0.5 – 5 hours Permanent Off

The load is permanently switched off for a period of 0.5 to 5 hours (or until manual deactivation).

In principle, this function behaves like the "Permanent Off" function, except that it is automatically deactivated after a set time and switches to automatic mode ("AUTO" function). Manual deactivation is therefore not actually necessary.

Function: Impulse operation

If impulse operation is activated, the load is only switched on for a short time (about 0.5 seconds) when presence is detected. A longer-lasting detection of motion leads to the switch-on impulse being repeated at certain intervals. If the Day Mode setting is also selected, the motion evaluation is always independent of brightness. This function can be used in motion and presence detector mode to monitor other rooms, e.g. whether a customer is in the store, for example, in conjunction with a call button.

Function: Switch-off pre-warning

With the switch-off pre-warning, the lighting is not switched off immediately at the end of motion detection and after expiry of the delay time, but only after an advance warning with a light flashing three times every ten seconds (switching insert) or dimming down of the lighting (dimming insert). The switch-off pre-warning warns the person in the room that the lighting will be switched off shortly. The person therefore has the option of activating the delay time (e.g. by moving) to prevent the lighting from switching off (according to DIN 18015-2).

Function: Presence simulation

In recording mode (inactive mode), the switching operations are recorded in automatic mode, which are triggered by the presence of people. In playback mode, the recorded operations are played back. In playback mode, the load is only switched on when the brightness level is reached (brightness < switch-on threshold) for each switching operation, and switched off again after the set delay time has elapsed. For example, if you are away for a long time (e.g. on holidays), you can simulate people in the building and deter potential intruders.

If movement is detected in playback mode, it is also evaluated and the lighting adjusted accordingly. In presence simulation, the alarm function can also be activated.

Function: Alarm mode

When alarm mode is activated, the motion detector switches the load into flashing mode (approx. one second on, one second off) for the set delay time. In addition, the LED status (red LED) signals the triggering of the alarm by flashing quickly (about 0.5 seconds on, 0.5 seconds off) until the alarm function is deactivated. In alarm mode, motion is evaluated regardless of brightness.

The alarm mode is usually activated in a person's absence. If unauthorised persons gain access to the building, they will be unsettled by the sudden activation of the load. Neighbours can be alerted to an unauthorised entry. If you activate alarm mode using a time-switch function, you must also deactivate it again using a time-switch function.

Function: Hotel light or orientation light

With the hotel/orientation light function, the light is switched between two brightness values when motion is detected.

The hotel/orientation light function is designed as a convenience function in buildings such as hotels. The lighting is permanently switched on as an orientation light with low brightness. When motion is detected, the motion detector switches the light to a higher, preset brightness value. To use the hotel light/orientation light function, the device must be combined with a dimming insert. For all switch-on commands, the light switches to the pre-set brightness value. If no motion is detected, the lighting is dimmed again to the brightness of the orientation light after a delay time has elapsed.

The setpoint for the orientation light is 20% of the factory setting.

When the motion detector is in presence detector mode, a power-off command dims the lighting to the orientation light level and does not switch it off completely.

With the "Permanent Off" function, the lighting can be switched off completely.

Function: Night light

With the night light function, the light is switched on during programmable periods of time with a low brightness level when motion is detected. A typical application is the night-time trip to the bathroom. The design of living spaces is in accordance with VDI/VDE 6008, Page 3 and VDE AR-E 2757-8.

To use the night light function, the device must be combined with a dimming insert. For all switch-on commands, the motion detector switches on the light to the night-time brightness level. The value is factory set to 20% and can be adjusted using the Gira System 3000 App.

A switched-on load can still be dimmed using the auxiliary units, and can be set to be lighter or darker than the night-time brightness level.

Constant light control function

The motion detector continuously measures the amount of artificial light and daylight. If the set switching threshold is not reached, the motion detector switches on the light when motion is detected and adjusts it so that the desired brightness value is reached.

The brightness in the room therefore remains constant, regardless of the amount of daylight entering the room. It should remain the same over a monitored area (e.g. a desk), even when the ambient light is variable (e.g. sunlight/daylight).

This leads to more convenience, constantly-adapted lighting and energy savings. Typical applications: offices, conference rooms, production areas, etc.

To use the constant light control function, the device must be combined with a dimming insert. The desired brightness value to which the constant light control should adjust is set using the Gira System 3000 App. The constant light control always switches on at the saved switch-on value (brightness value) and then controls to the set brightness setpoint.

Temporarily changing the brightness value: The light can be dimmed by connecting a 2-wire auxiliary insert with operating button to the auxiliary unit terminal 1 of the dimming insert. The value set this way is the new brightness value to which the constant light control should be set. This is maintained until the device switches off after the delay time elapses. The next time the device is switched on, the constant light control will return to its original brightness value.

Time-switch functions

The hotel function, alarm mode, presence control, night light function, etc. can be activated for a certain period of the day.

This allows you to create a schedule for the different operating modes and functions for each individual day of the week. Switching points can be set. You can activate one function per switching point, e.g.:

- Mon – Fri: 10.30 pm Night light function ON
- Sat & Sun: 12 am midnight Alarm function ON
- Sat & Sun: 5.30 am Alarm function Off
- Mon – Sun: 6 am Automatic

The programmes and settings entered are saved even in the event of a power failure.

Lock time

If a motion detector has switched off the lighting, the motion detection is deactivated for a short locking time in order to prevent the motion detector from detecting the lamps that are cooling down in the detection field as thermal motion and switching them back on immediately. The required locking time is automatically determined by all motion detectors and is 0.3 to max. three seconds.

4.4.3 Setting up detection fields

If a motion detector is supplied with mains voltage, it starts a process of calibrating the environment for a maximum of 60 seconds. During this time no movement is detected and no switching command is accepted. During the calibration, the lighting is switched off; this is indicated by a red LED behind the detection lens.

Motion detector top unit Standard and Komfort BT

At the motion detector's nominal mounting height of 1.10 metres or 2.20 metres, the following results from the mounting position:

- A detection field with a detection angle of 180°
- A frontal surveillance range of up to 30 metres
- A side surveillance range of up to 15 metres

Options for restricting the detection field

If necessary, you can limit the detection field of the motion detectors. That gives you even more flexibility in your choice of the installation site.

The scope of delivery of the 1.10 m motion detector top units includes a clip-on panel that limits the detection field to an angle of 90°. The clip-on panel can be mounted either on the right or on the left. With the motion detector top unit 2.20 m Komfort BT, you can also activate/deactivate the individual sensors via app. This limits the detection range on the left and right by 60°. The detection field of the motion detector top unit 1.10 m Komfort BT can also be individually adjusted via the app.

Presence and motion detector 360° top unit BT

The presence and motion detector 360° top unit BT has a surveillance space of 20 metres in diameter on the ground with a mounting height of three metres. You can set the detection field using the Gira System 3000 App or use the covering panel to restrict the detection field.

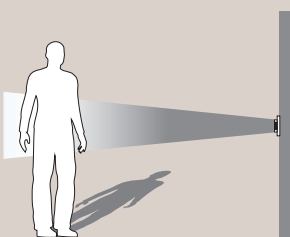

Motion detector top unit 1.10 m

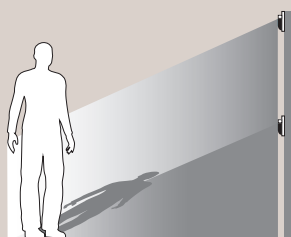

Motion detector top unit 2.20 m

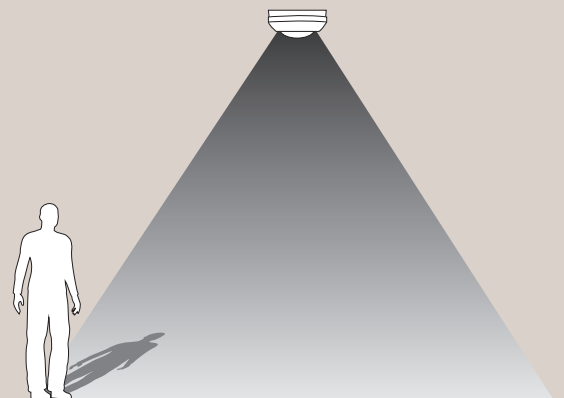

Presence and motion detector 360° top unit BT

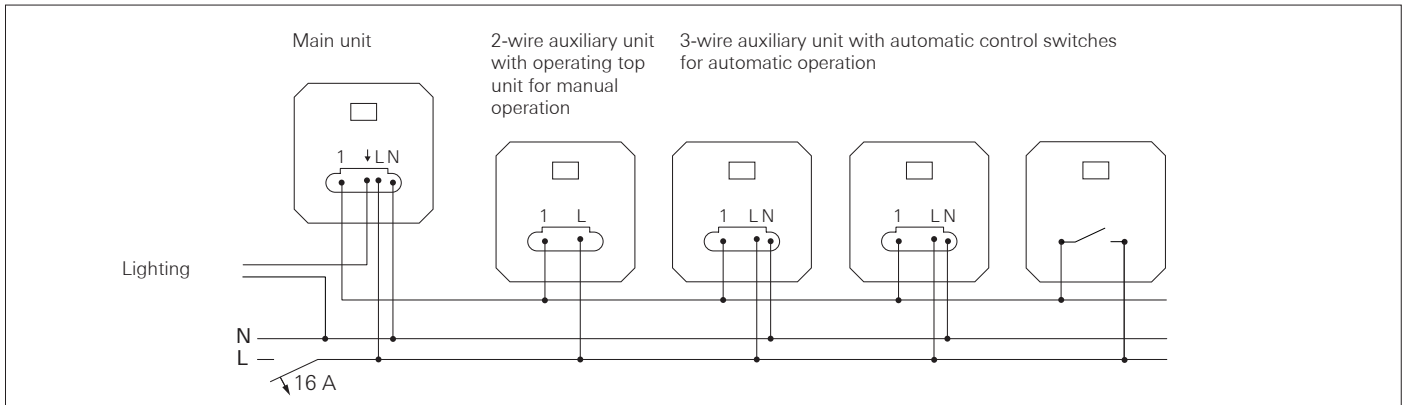

The auxiliary inserts extend the detection range and trigger the lighting control via the main unit.

4.4.4 Settings

The motion detectors and presence detectors can be mounted for a wide range of applications and in different positions. To ensure that they are a perfect fit for the individual application and installation site, the set parameters can be modified individually. Details can be found in the respective operating instructions.

Delay time

The delay time defines how long the lights remain on after all motion is detected.

The delay time of the motion detector top unit Standard is set to two minutes. You can set the delay time from ten seconds up to 60 minutes in the Gira System 3000 App for the motion detector top unit Komfort BT.

The motion detector top unit Komfort BT also has a dynamic self-teaching delay time.

The function uses the movements detected in the past to determine a delay time within specified limits. If presence is detected for a longer period of time, the delay time is increased cyclically, and cyclically reduced in the event of a longer absence. This optimises the energy efficiency and user convenience of the automatic switching.

Sensitivity

The sensitivity function allows you to set the range for the motion detectors and prevent faulty switching due to excessively sensitive monitoring.

With the motion detector top unit Komfort BT, the sensitivity of the individual infrared sensors can also be individually set using the Gira System 3000 App.

Brightness threshold

By setting the brightness threshold, you can adjust the motion detectors to the switch-on brightness level required for the respective application. A lower brightness level is usually required in transit areas compared with work areas (e.g. office or workshop).

Walking test

The walking test function allows you to check the detection range and the detection response and, if necessary, adjust them using the corresponding settings (detection field and sensitivities). The walking test is carried out independent of brightness. The lighting is switched on for one second each time motion is detected.

4.4.5 Motion detector top unit Standard and relay switching insert, 2-gang

Saving the switch-on brightness (brightness value)

In conjunction with a dimming insert, you can save an individual switch-on brightness level. This lets you create your own standard. If required, you can adjust the brightness level using operating top units or conveniently via the Gira System 3000 App on your smartphone.

Saving and retrieving user settings

The motion detector top unit Komfort BT offers the option of saving the current configuration on the device and in the Gira System 3000 App.

Tip: Save the configuration after start-up.

If the end customer changes the settings later, they always have the option of restoring the settings made by the installer.

The following settings can be saved:

- Operating function
- Operating mode
- Detection field settings (PIRs)
- Sensitivity settings (PIRs)
- Switch-on brightness (brightness value)
- Brightness threshold
- Delay time
- Dynamic delay time
- Walking test
- Impulse operation
- Switch-off pre-warning
- Presence simulation
- Hotel/orientation light function
- Night light function
- Constant light control
- Alarm mode function

In combination with a motion detector top unit Standard, the relay switching insert, 2-gang operates as it would with a simple operating top unit. Both outputs are switched depending on brightness. The motion detector top unit switches on output a1 and switches it off after the 2-minute delay time saved to the motion detector has elapsed. Output a2 switches immediately or with a time delay depending on output a1.

From relay status V02 (index I01) or higher, the motion detector Standard switches on output a1 depending on brightness and switches it off after the 2-minute delay time saved to the motion detector has elapsed.

Output a2 switches on in the event of movement, regardless of brightness, and after the switch-on delay has elapsed. After the switch-off delay set in the insert for output a2 has elapsed, the motion detector switches the output off again.

Switch-on delay

The switch-on delay for output a2 is switched on or off at the insert. To do so, an operating top unit is plugged onto the relay switching insert, 2-gang instead of the motion detector top unit and is replaced with the motion detector top unit after the switch-on delay has been set.

Delay time

The delay time for output a2 is set on the insert with the TEST button.

4.4.6 Motion detector top unit Komfort BT and relay switching insert, 2-gang

In the event of movement, the motion detector top unit switches on output a1 depending on brightness and output a2 regardless of brightness and with a time delay. After the delay times saved to the motion detector have elapsed, the motion detector switches the outputs off again.

Switch-on delay

The switch-on delay for output a2 is controlled by the motion detector top unit and is factory-set to 2 minutes. Output a2 only switches on if movements are detected during the current switch-on delay.

Delay time

The delay time for output a1 is set via app in the motion detector top unit. The delay time starts elapsing when no more motion is detected. The delay time for output a2 is saved to the motion detector top unit and is factory-set to 5 minutes. The delay time for output a2 starts elapsing when no more movement is detected and output a1 is switched off.

4.4.7 Pairing the motion detector top unit Komfort BT

The motion detector top units Komfort BT can be paired with a smartphone via Bluetooth. The Gira System 3000 App makes start-up and managing settings a breeze.

To pair the motion detector top unit Komfort Bluetooth with a smartphone, proceed as follows:	
1.	<p>Motion detector top unit 1.10 m Komfort BT: Slide the sliding switch to the ON/AUTO position for more than four seconds.</p> <p>Motion detector top unit 2.20 m Komfort BT: Press the ON/AUTO button for more than four seconds.</p> <p>Presence and motion detector 360° top unit BT: Press the Bluetooth  button for more than four seconds.</p>
2.	<p>Search for available devices using the app and follow the instructions on the display. Each Bluetooth device can manage up to eight smartphones.</p>

5 // System 3000 Shading

As a logical development of the well-known blind control system, System 3000 supplies all components for modern shading control system on a modular basis designed to suit the needs of the trade.

The two blind inserts with and without an auxiliary input can each be combined with the different covers.

Featuring the diverse Gira designs, they can be selected to match the rest of the electrical installation.

5.1 Device overview

Top units	Order no.
System 3000 operating top unit	5360 ..
System 3000 operating top unit arrow symbols	5361 ..
System 3000 touch top unit	5365 ..
System 3000 operating top unit Memory arrow symbols	5363 ..
System 3000 blind timer and timer Display	5366 ..
System 3000 operating top unit BT	5368 ..
System 3000 blind timer and timer BT	5367 ..
eNet wireless operating top unit arrow symbols	5494 ..
eNet wireless operating top unit	5495 ..
eNet wireless operating top unit Memory arrow symbols	5492 ..
eNet wireless operating top unit Memory	5493 ..

Inserts	Order no.
Blind control insert with auxiliary input	5414 00
Blind control insert without auxiliary input	5415 00

Sensor	Order no.
System 3000 brightness and temperature sensor BT	5466 02

System 3000 blind control insert without auxiliary input

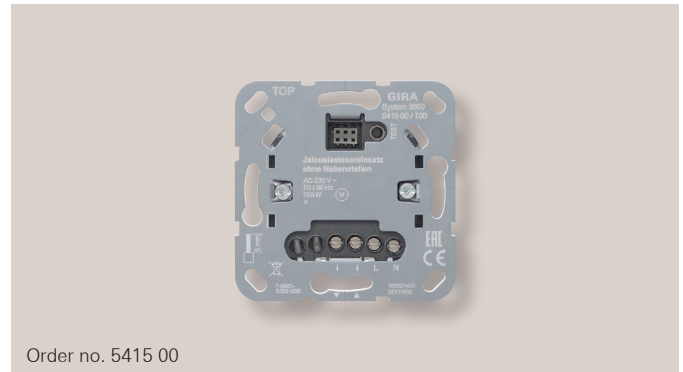

The blind control insert without auxiliary input allows you to control hangings manually using mechanical control buttons, via Bluetooth, or individually with a timer. With its low installation depth of only 24 millimetres, this insert offers optimum connection options. The stable mounting plate ensures fast and safe installation. The blind control insert without auxiliary input can control blinds, shutters and awnings.

Functions at a glance:

- Intelligent insert for operation with operating top unit and System 3000 blind timer and timer
- Data-based, bidirectional communication of top units and inserts
- Test operation is possible without top unit
- Reverse polarity function of the motor outputs (up/down) using the TEST button in the event of an incorrect connection. This eliminates the need to remove the inserts again.
- Energy-saving power supply unit
- Motors: maximum 700 W
- AC 230 V, 50/60 Hz
- VDE mark
- Screw terminals
- For controlling a hanging
- Not suited for group or central control

System 3000 blind control insert with auxiliary input

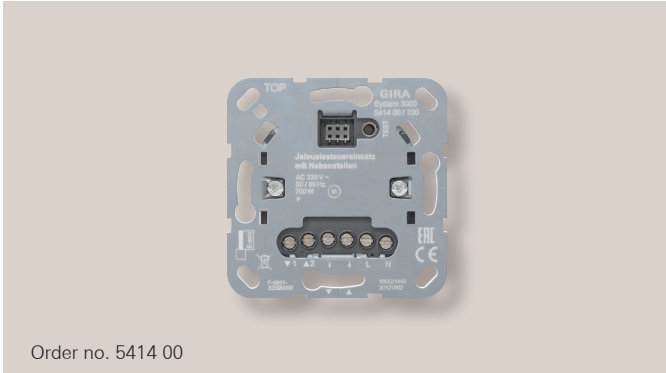

System 3000 operating top unit System 3000 operating top unit arrow symbols



With the blind control insert with auxiliary input, you can manually control hangings with mechanical control buttons, individually or centrally, via Bluetooth or via a timer. With its low installation depth of only 24 millimetres, this insert offers optimum connection options and yet a stable mounting plate.

The blind control insert with auxiliary input can control blinds, shutters and awnings and can be upgraded using the auxiliary input to form a group and central control system.

Functions at a glance:

- Intelligent insert for operation with operating top unit and System 3000 blind timer and timer
- Data-based, bidirectional communication of top units and inserts
- Test operation is possible without top unit
- Reverse polarity function of the motor outputs (up/down) using the TEST button in the event of an incorrect connection. This eliminates the need to remove the inserts again
- Energy-saving power supply unit
- Installation on different external circuits for local and central control is possible. There is no need to keep different fuse circuits in mind
- The installation can be carried out with different RCCBs
- Each blind control insert can be used without restriction as a main or auxiliary unit
- Motors: maximum 700 W
- AC 230 V, 50/60 Hz
- VDE mark
- Screw terminals

The operating top unit is a single-channel top unit for System 3000 inserts.

It can be operated at the top, bottom and additionally across the entire surface.

Functions at a glance:

- Shading control with corresponding inserts
- Lighting control with corresponding inserts
- Continuous operating concept
- Top unit for 2-wire or 3-wire auxiliary insert

System 3000 touch top unit



The touch top unit is a single-channel attachment for all System 3000 inserts. It consists of a capacitive touch surface with an LED light bar as a status display in the typical Gira design. It is operated by lightly touching or swiping the touch surface.

Functions at a glance:

- Lighting control with corresponding inserts
- Shading control with corresponding inserts
- Continuous operating concept
- Top unit for 3-wire auxiliary insert
- Three brightness values can be saved with System 3000 dimming insert
- The runtime and an individual intermediate position can be saved using the System 3000 blind control insert
- Blocking function, with System 3000 blind control insert
- Status display using LED light bars for indicating the brightness or hanging position
- Night mode, i.e. the status display is not permanently illuminated

System 3000 operating top unit Memory arrow symbols



The operating top unit Memory is a single-channel top unit for all System 3000 inserts. The top unit consists of a split rocker that looks like a rocker, 2-gang. Each side of the rocker is assigned a colour LED, which serves as a function display, status display and orientation light. The rocker can be operated at the top, bottom and additionally across the entire surface.

Functions at a glance:

- Shading control with corresponding inserts
- Lighting control with corresponding inserts
- Continuous operating concept
- Top unit for 3-wire auxiliary insert
- Operation is both manual and automatic
- Night mode, i.e. the function and status LED lights are not permanently illuminated
- Blocking function to deactivate all automatic, auxiliary unit and Memory functions
- Contains a memory function with two switching times that are repeated every 24 hours

System 3000 blind timer and timer Display



The blind timer and timer Display is a single-channel top unit for System 3000 inserts. It consists of a capacitive touch surface in the typical Gira design with an illuminated display.

Functions at a glance:

- Shading control with corresponding inserts
- Lighting control with corresponding inserts
- Top unit for 3-wire auxiliary insert
- Menu control, dialogue-led
- Two time blocks: Mon to Fri, Sat to Sun:
 - For blind inserts, one time block consists of one up/down time combination
 - For switching and dimming inserts, a time block consists of two on/off time combinations
- Astro function:
 - 18 countries can be selected
 - Setting a time difference for morning and evening
- Quick save: Adopting the current time as the switching time
- Automatic setting of summer and winter time, which can be switched off by the user
- Illuminated segment display: Enables reliable reading in dark installation locations
- Touch-sensitive surface: Operation by six operating surfaces with printed symbols
- Evaluation of auxiliary units
- Display switches off after two minutes or switches to permanent display of the time
- Blocking function to deactivate all automatic, auxiliary unit and time program functions
- Power failure: In the event of a power failure, the time and date are saved for four hours. All other values are saved in power outage safe mode
- Fast switching between automatic and manual actuation
- Display of the next switching time or raising/lowering time

System 3000 operating top unit BT

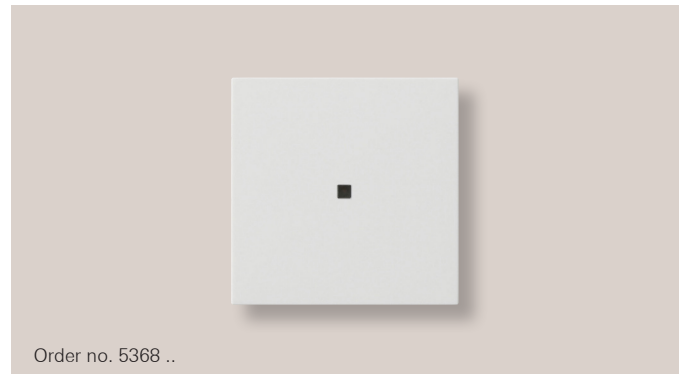

The operating top unit BT is a single-channel top unit for System 3000 inserts. The top unit consists of a rocker with a status LED. The rocker can be operated at the top, bottom and additionally across the entire surface. You can set and program this easily by Bluetooth using your smartphone and the Gira System 3000 App.

Functions at a glance:

- Lighting control and configuration with corresponding inserts
- Shading control and configuration with corresponding inserts
- Top unit for 3-wire auxiliary insert
- Connected sun protection and twilight function with System 3000 brightness and temperature sensor BT
- 40 switching times, at each switching time blind and slat positions or switching and dimming values can be saved
- Night mode, i.e. the status LEDs are not permanently illuminated
- Operation of the System 3000 inserts via Gira System 3000 App with status feedback in values (0 to 100 per cent, On/Off)
- Switch-on brightness can be saved with dimming insert
- Copying of switching times via Gira System 3000 App to other operating top units BT
- Astro function using GPS data in the Gira System 3000 App for every switching time
- Automatic setting of summer or winter time and automatic time synchronisation via the Gira System 3000 App
- Random function
- Additional parameters can be set depending on the System 3000 insert

System 3000 blind timer and timer BT



The blind timer and timer BT is a single-channel top unit for all System 3000 inserts. The top unit consists of a split rocker that looks like a rocker, 2-gang. The rocker can be operated at the top, bottom and additionally across the entire surface. The colour LED at the right shows the different functions, the colour LED at the left indicates the respective status. You can set and program this easily by Bluetooth using your smartphone and the Gira System 3000 App.

Functions at a glance:

- Shading control and configuration with corresponding inserts
- Lighting control and configuration with corresponding inserts
- Top unit for the 3-wire auxiliary unit
- Sun protection and twilight function linked with System 3000 brightness and temperature sensor BT
- 40 switching times, at each switching time blind and slat positions or switching and dimming values can be saved
- Night mode, i.e. the function and status LED lights are not permanently illuminated
- Blocking function to deactivate all automatic, auxiliary unit and time programme functions
- Operation of the System 3000 inserts via Gira System 3000 App with status feedback in values (0 to 100 per cent, On/Off)
- Switch-on brightness can be saved with dimming insert
- Copying switching times via Gira System 3000 App to other blind timers and timers Bluetooth
- Astro function using GPS data in the Gira System 3000 App for every switching time
- Automatic setting of summer and winter time, and automatic time synchronisation via Gira System 3000 App
- Random function
- Additional parameters can be set depending on the System 3000 insert

eNet wireless operating top unit eNet wireless operating top unit arrow symbols

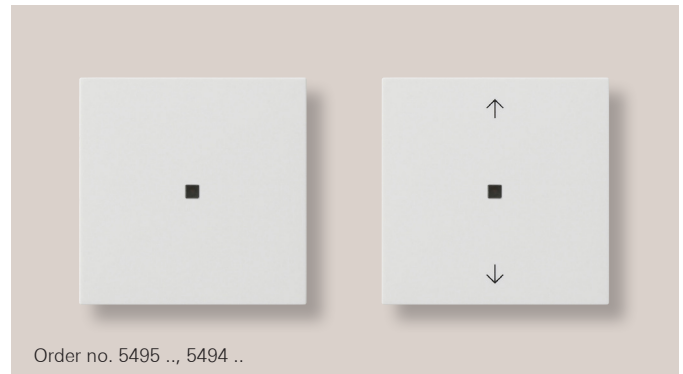

The eNet wireless operating top unit is a single-channel top unit for integrating System 3000 inserts into the eNet wireless system. The top unit consists of a rocker with a status LED. The rocker can be operated at the top, bottom and additionally across the entire surface. By integrating it into the eNet wireless system, a variety of different functions and settings are possible, especially in connection with an eNet server.

Functions at a glance:

- Lighting control with corresponding inserts
- Shading control with corresponding inserts
- Top unit for 3-wire auxiliary insert
- Status feedback to wireless transmitter
- Evaluation of auxiliary inputs
- Integration into light and blind scenes

With eNet server (depending on insert):

- Repeater function
- Adjustment time when changing directions
- Operation locks
- Deactivate auxiliary unit evaluation
- Position for sun protection, twilight, lock-out protection and wind alarm
- Maximum and minimum brightness
- Dimming speed and dimming ramp up/down
- Switch on/off delay
- Switch-off pre-warning
- Permanently on, permanently off
- Hotel function
- Delay time
- Light control
- Fully encrypted wireless transmission (AES-CCM)

eNet wireless operating top unit Memory eNet wireless operating top unit Memory arrow symbols

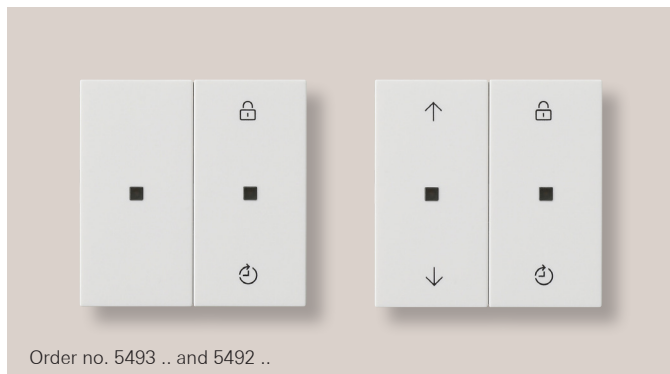

The eNet wireless operating top unit is a single-channel top unit for integrating System 3000 inserts into the eNet wireless system. The top unit consists of a split rocker that looks like a rocker, 2-gang. Each side of the rocker is assigned a colour LED, which serves as a function display, status display and orientation light. The rocker can be operated at the top, bottom and additionally across the entire surface. By integrating it into the eNet wireless system, a variety of different functions and settings are possible, especially in connection with an eNet server.

Functions at a glance:

- Lighting control with corresponding inserts
- Shading control with corresponding inserts
- Top unit for 3-wire auxiliary insert
- Status feedback to wireless transmitter
- Evaluation of auxiliary inputs
- Integration into light and blind scenes
- Night mode, i.e. the function and status LED lights are not permanently illuminated
- Blocking function to deactivate all automatic, auxiliary unit and Memory functions
- Includes a Memory function with two switching times, repeated every 24 hours

With eNet server (depending on insert):

- Repeater function
- Adjustment time when changing directions
- Operation locks
- Deactivate auxiliary unit evaluation
- Position for sun protection, twilight, lock-out protection and wind alarm
- Maximum and minimum brightness
- Dimming speed and dimming ramp up/down
- Switch on/off delay
- Switch-off pre-warning
- Permanently on, permanently off
- Hotel function
- Delay time
- Light control
- Fully encrypted wireless transmission (AES-CCM)

System 3000 brightness and temperature sensor BT



The brightness and temperature sensor BT is used to record brightness and temperature levels. It can be affixed to window panes without tools using an adhesive pad and is powered by a lithium battery. As a result, it is independent of the mains power supply and can be attached anywhere without unsightly lines.

The wireless range in a room is about ten metres. With the brightness and temperature sensor BT, you can add various functions to the operating top unit BT, blind timer and timer BT and room temperature controller BT.

The surface-mounted housing for the System 3000 brightness and temperature sensor makes it possible to use the sensor outdoors.
Functions at a glance:

- Measured brightness and temperature values can be transmitted to one or more operating top units BT or blind timer and timers BT via Bluetooth. If the brightness value exceeds or falls below the set value, this triggers the sun protection or twilight function. The hangings move to a defined position or the lighting is switched.
- External room temperature sensor for the room temperature controller BT.
- Transmits the current brightness value (5 to 80,000 lx)
- Transmits the current temperature value (-5 °C to +55 °C)
- Sun protection function enables the automatic lowering of a hanging in the event of excessive sunlight:
 - Hanging moves to the sun protection position if the brightness threshold is exceeded for more than two minutes
 - Hanging is raised again if the brightness falls below the threshold for more than 15 minutes
- Brightness threshold can be linked to the temperature measurement. Shading is only triggered if the set temperature and brightness threshold are exceeded
- Twilight function enables automatic lowering of the hanging or switching on of the lighting:
 - Hanging moves to the twilight position if the twilight threshold is not reached for more than four minutes.
 - Hanging is raised again if the twilight threshold is exceeded for at least four minutes.
 - Lighting switches on if the twilight threshold is not reached for four minutes.

5.2 Electrical connection

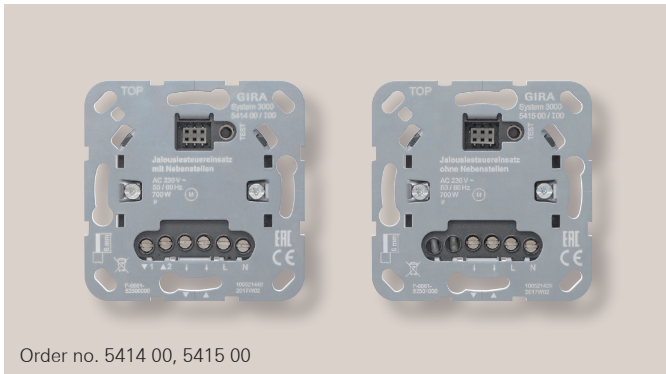

The blind control inserts have four terminals L, N, ↓ and ↑ for controlling a motor for the shading system. In addition, the blind control insert with auxiliary input provides two terminals 1 and 2 for connecting auxiliary units.

The external conductor is connected to L and the neutral conductor to N. The two terminals ↓ are available for connecting a shading system motor provided by the customer.

If the hanging moves in the wrong direction after start-up, the insert's reverse polarity function can be used. The reverse polarity function changes the direction of travel of the hanging, so you no longer have to change the conductors at the terminals ↓. The new direction of travel is saved in a power outage safe mode.

5.2.1 Connecting the insert

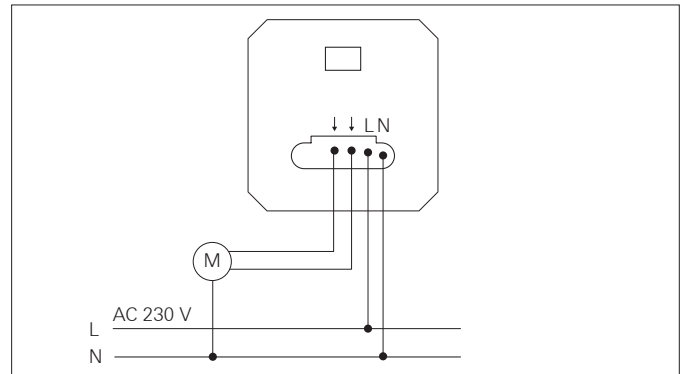

1. Connect the blind control insert according to the connection diagram.
2. Mount the blind control insert in a device box.
The connection terminals must face downwards. Thanks to its small installation depth of only 24 mm, there is enough connection space.
3. Switch on the mains voltage.
4. You can also use the TEST button to control the connected motor without a top unit in order to test the wiring and set the end position of the motor.
 - If you press TEST for less than one second, the hanging will move towards the lower end position.
 - If you press TEST for more than one second, the hanging will move towards the upper end position.
 - If the motor is moving in the wrong direction, press the TEST button for more than ten seconds. This reverses the motor outputs (up/down), meaning that it is not necessary to remove the inserts again.
5. Depending on the type of hanging, set the upper and lower end position. Details can be found in the operating instructions for the motor. You set the desired end position on the motor.
6. Finally, mount the cover frame and the top unit in a de-energised state.

Note:

When connecting a wind sensor:

As long as there is an Up command on auxiliary input 2 because of a wind alarm, the blinds can neither be operated manually nor automatically. The blocking of the manual actuation serves to protect the hangings.

5.2.2 Requirements of the shading motor

The motors used must be equipped with a limit switch (mechanical or electronic), which switches the de-energised motor in the end position. After switching on the relays, the mains voltage is available for raising or lowering the shading.

The relays of the shading control switch motors up to 700 W. Also note this value when operating several motors.

Note the maximum power-on time (often referred to as "ED" in technical data). Frequent raising and lowering can cause the motors to overheat, switching them off via an integral thermal switch and limiting their function again until they have cooled down.

Depending on the design of the motor, the cooling process can take up to 30 minutes. If you want to switch motors at the same time, the motors must be suitable for this. Alternatively, use cut-off relays.

5.3 Tips for operation

In addition to the actual raising/lowering of hangings, you can also adjust slats, depending on the hanging, and temporarily deactivate automatic or programmed switching operations via the blocking function. Moreover, you can set an individual ventilation position in which the hanging automatically stops.

5.3.1 Adjusting hangings and slats

1. Press the upper or lower half of the button for more than one second to move the hanging up or down.
2. Press the button again to stop the hanging at a desired position. Otherwise, the hanging moves to the upper or lower end position.
3. Press the upper or lower half of the button for less than one second to adjust the slats.

If a ventilation position is already saved, the hanging stops being lowered from the upper position when the ventilation position is reached.

5.3.2 Blocking function

With the blocking function, the user can fix the blind in the upper end position. All automatic functions as well as operation using auxiliary units are deactivated until the blocking function is switched off again. This will prevent the patio door shutters from being automatically lowered while residents are still in the garden, for example.

Activating and deactivating the blocking function

The blocking function disables auxiliary unit operation (wind alarm remains unaffected) and disables all automatic operations. Manual actuation is still possible via the buttons. If the blocking function button is pressed for more than four seconds, the blocking function is activated. As long as the blocking function is active, the LED function lights up red.

5.3.3 Ventilation position

The ventilation position is any position between the the upper and lower end position where the hanging stops automatically when being lowered. This lets the room continue to be ventilated/not be completely darkened, for example. After the hanging has stopped in the ventilation position, it can also be lowered to the bottom end position through a subsequent command. In combination with the operating top unit BT or the blind timer and timer BT, the saved hanging positions can be controlled from any position using the Gira System 3000 App.

Setting the ventilation position

To set the ventilation position, proceed as shown in the illustration on the right.

If you save a new ventilation position, the saved value will be overwritten.

5.3.4 Reversal time

In order to prevent overloads from occurring when reversing the direction of rotation while raising/lowering, which could damage the insert and the motor, there is a reversal pause of approx. one second between switching the drive off and on again.

5.3.5 Setting the ventilation position

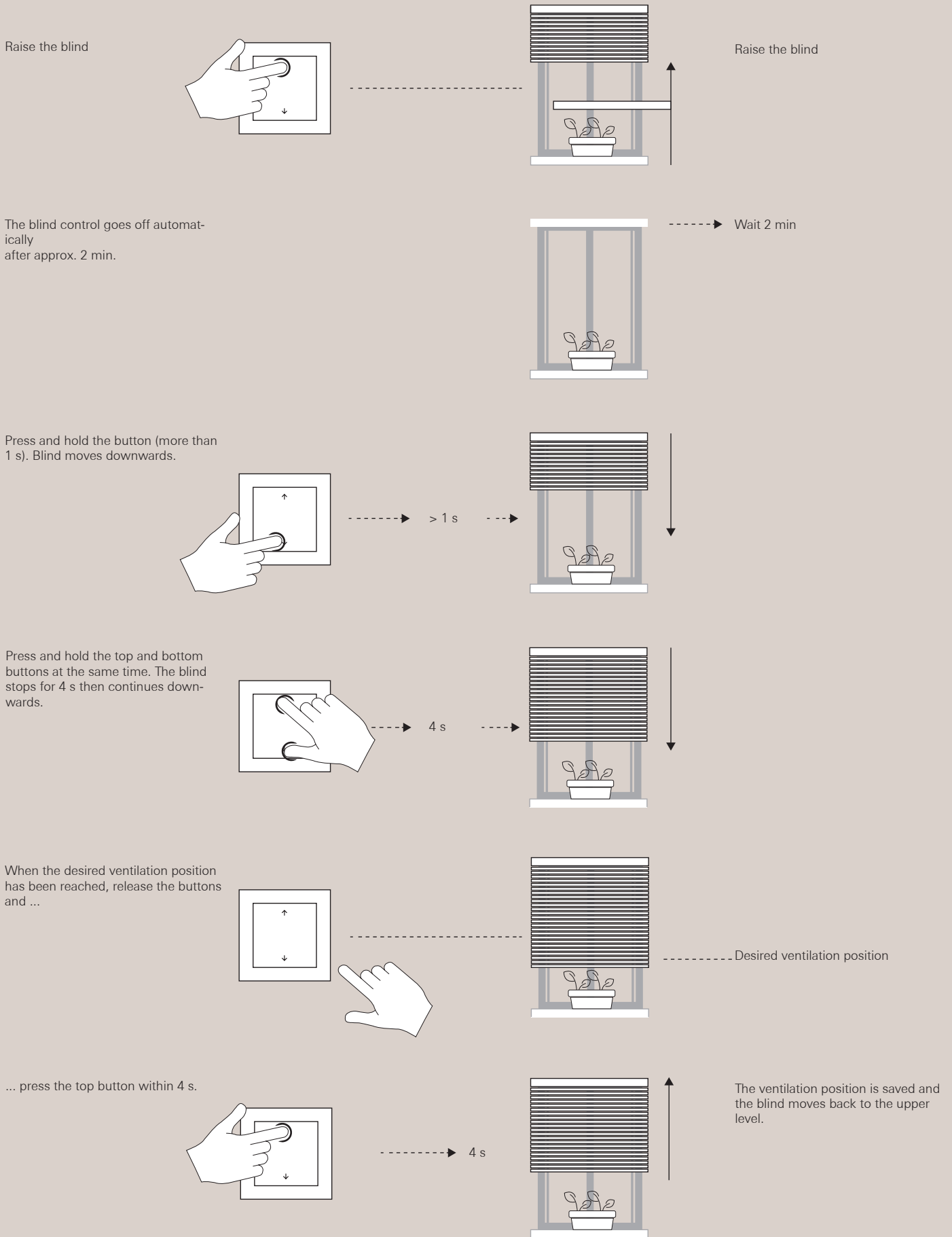

5.4 Control options

5.4.1 Individual control

The simplest variant of shading control is individual control. If only a few blinds are to be used, the individual control option offers a cost-effective variant.

The individual control option (blind control insert without auxiliary input with any top unit) switches a shading system into a self-contained system. If several motors are connected to a blind control insert, the maximum connection power of 700 W must also be taken into account. The motors must be suitable for parallel operation. Alternatively, use cut-off relays.

By selecting the top unit, individual control can be realised as a manual, remote-controlled or sensor-controlled variant.

5.4.2 Group and central control

Group or central control refers to cases where individual blind control inserts are interconnected via the auxiliary inputs. Since an auxiliary input is required, group and central controls can only be implemented with the blind control insert with auxiliary input. An auxiliary unit can control multiple blind control inserts simultaneously and has the advantage that it can be cascaded in any way, so that the blinds can be flexibly controlled individually, per room, per floor or per building, even with more than three levels of hierarchy.

With group control, a blind control insert with any top unit acts as a master, which transmits the control commands to all connected blind control inserts to which the motors are connected. The blinds can be controlled individually on site via the downstream blind control inserts.

5.4.3 Central control

For very large systems, e.g. as in office buildings, all blinds can be centrally controlled. If a wind sensor is connected, the entire system can be protected from storms globally. A group control is installed on each floor and the respective masters are centrally grouped together with a higher-level master. The following control options are available: centrally via the master, floor by floor via group control, or individually on site.

Individual control

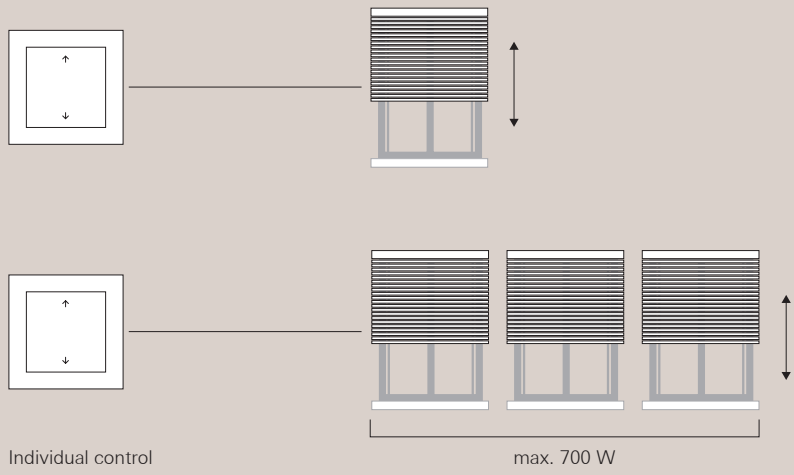

Individual control

max. 700 W

Group control

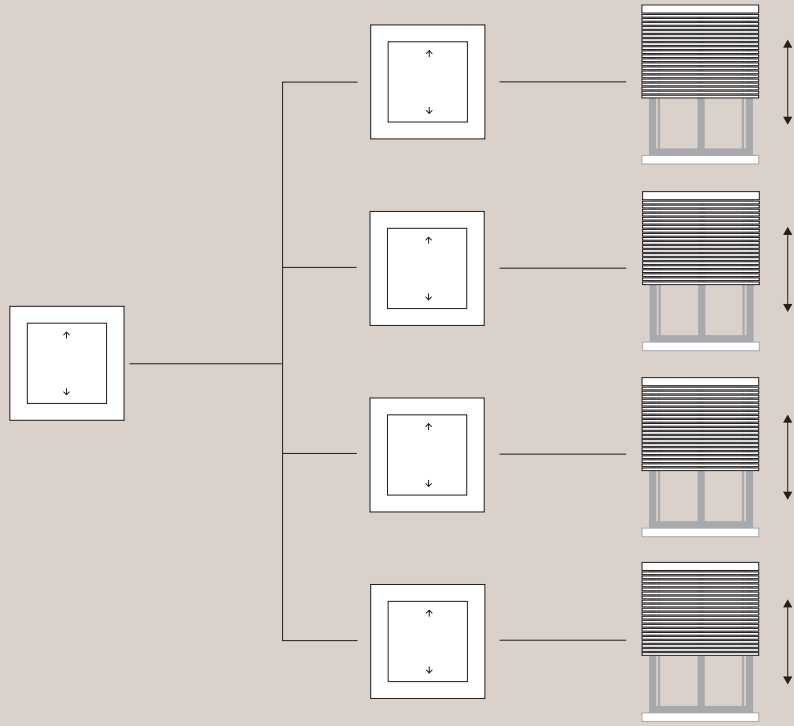

Group control

Individual control

Central control

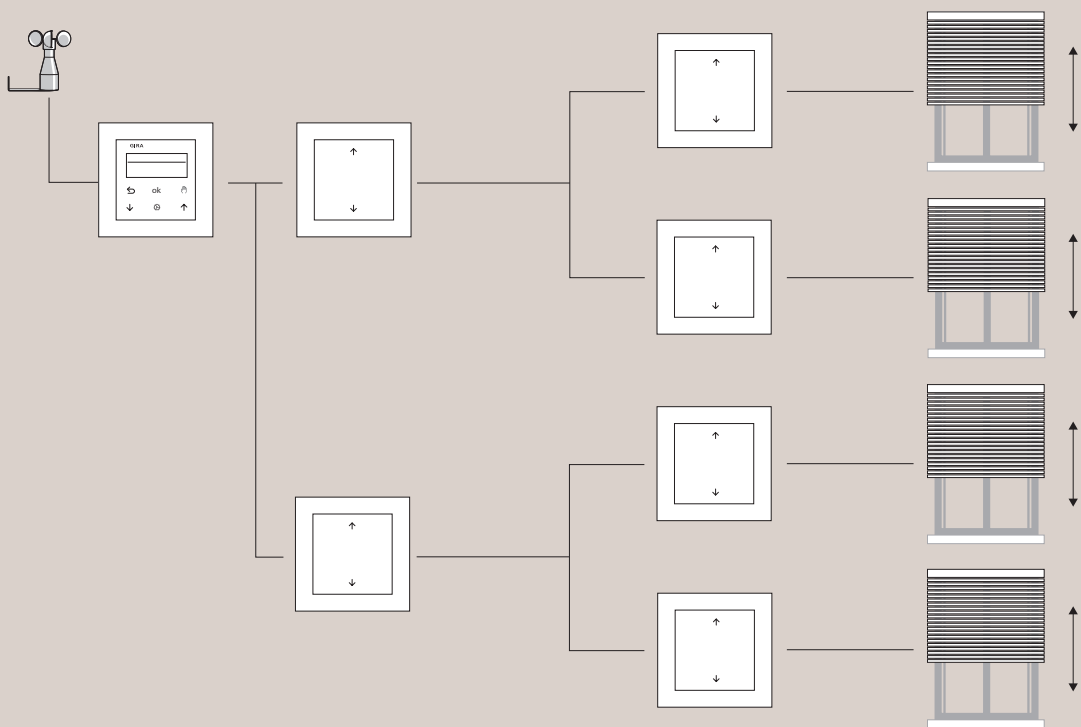

Central control

Group control

Individual control

5.4.4 Connecting auxiliary units

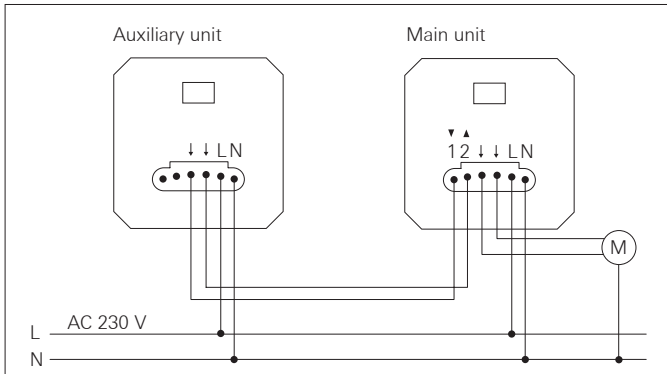

In addition to the terminals L, N and the motor connection, the blind control insert with auxiliary input provides two terminals 1 and 2 for connecting auxiliary units. If the 230 V mains voltage is switched to one of these inputs, this triggers the corresponding motor travel direction. This makes it possible to control the blinds with a second operating element or to raise/lower multiple blinds individually or as a group. The motor runs as long as a mains voltage is supplied to the auxiliary input. Since the auxiliary input "On" terminal 2 can also be used to connect a wind sensor, this has the highest priority, even in terms of local operating elements.

The 230 V auxiliary inputs are galvanically isolated from the electronics via optical couplers and routed by the interface to the operating top unit. This allows the use of different external conductors (e.g. L1 + L2).

Mechanical and electronic auxiliary units can be connected to an auxiliary input. Mechanical auxiliary units are blind buttons or switches. These are suitable for connection and provide protection against unauthorised actuation. Disadvantages of the mechanical auxiliary units are that the buttons can only be operated manually during the entire running time and switches must be reset.

The System 3000 auxiliary unit uses the same concept at both operating points. In addition, various operating concepts can be combined with each other here, such as a blind timer and timer Display and an operating top unit Memory.

Caution!

Device damage due to improper connection!

Do not connect motors and auxiliary units at the same time, as the high AC voltages generated by the motors can damage the blind control insert.

Only connect the auxiliary units to the auxiliary inputs of the main unit. In this case, a blind control insert acts either as a group or central control device or as a motor control.

5.4.5 Integrating the device into group control

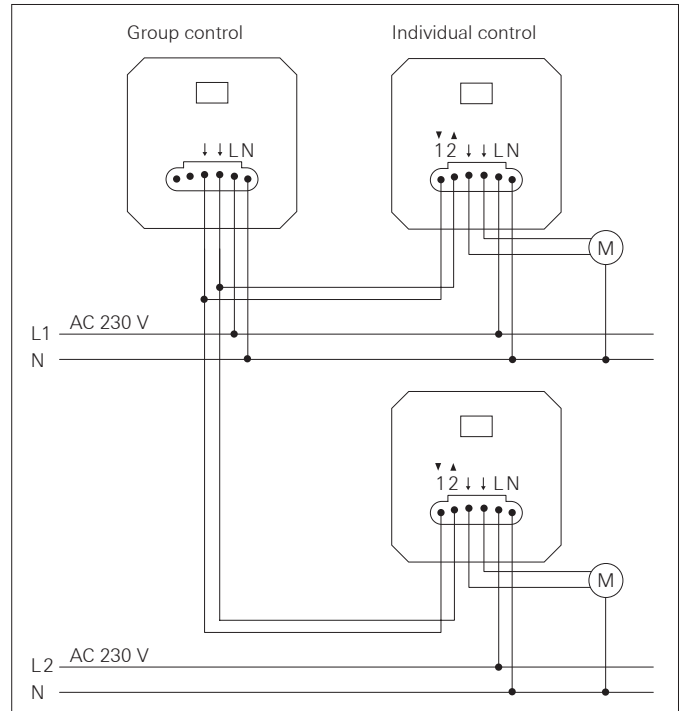

For a group control, connect the blind control inserts to each other as follows.

Note:

The blind control inserts can also be connected to different external conductors.

5.4.6 Connecting the wind sensor

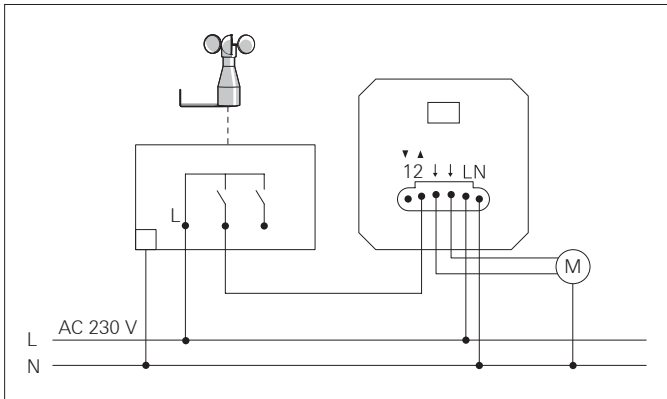

Wind sensors protect the blinds from destruction due to excessive wind. If the wind sensor reports excessive wind, the blinds are raised to a safe upper end position and locked there until the set threshold falls again.

1. Connect the wind sensor to the auxiliary input 2 according to the wiring diagram shown above.
2. If you want to use the wind alarm for all external blinds on a building, connect the wind sensor to auxiliary input 2 of the central control.

5.5 Functionality depending on the top unit

Note:

As long as there is an Up command on auxiliary input 2, the blinds can neither be operated manually nor automatically.

Further details can be found in section 5.7, "Wind alarm" on page 93.

Function	Blind control insert with or without auxiliary input			
	Operating top unit	Touch top unit	Operating top unit Memory arrow symbols	
Operation: Up, Down, Stop	X	X	X	
Ventilation position can be saved	X	X	X	
Runtime	120 seconds	120 seconds	120 seconds	
Blocking function		X	X	
Slat reversal	X	X	X	
Slat adjustment time		X		
Memory function			2 switching lines can be saved	
Timer				
Automatic summer/winter time change				
Astro function				
Random function				
Remote control				
Status feedback		LED light bar	LED	
Change to inverse operation				
Sun protection function				
Temperature-dependent sun protection				
Twilight function				
Misplacement protection		X	X	
Illuminated display				
Current time display				
Integration into scenes				
If-then rules				

1) Only in connection with the eNet server.

	Blind timer and timer Display	Operating top unit BT	Blind timer and timer Bluetooth	eNet wireless operating top unit	eNet wireless operating top unit Memory
	X	X	X	X	X
	X	X	X	X	X
	120 seconds	can be saved (1 to 600 seconds)	can be saved (1 to 600 seconds)	120 s (adjustable from 1 to 600 s using eNet server)	120 s (adjustable from 1 to 600 s using eNet server)
	X	using System 3000 App	X	using eNet wall, hand-held and universal transmitters, display with eNet SMART HOME App ¹⁾	X
	X	X	X	X	X
		using System 3000 App	using System 3000 App		using eNet SMART HOME App ¹⁾
	2 switching lines Mon – Sun can be saved				2 switching lines can be saved
	2 switching lines Mon – Fri and Sat – Sun can be saved	40 individual switching times can be saved using System 3000 App	40 individual switching times can be saved using System 3000 App	using eNet SMART HOME App ¹⁾	using eNet SMART HOME App ¹⁾
	X deactivatable	using System 3000 App	using System 3000 App	using eNet SMART HOME App ¹⁾	using eNet SMART HOME App ¹⁾
	for 18 countries	using System 3000 App	using System 3000 App	using eNet SMART HOME App ¹⁾	using eNet SMART HOME App ¹⁾
		using System 3000 App	using System 3000 App		
		using System 3000 App	using System 3000 App	using eNet wireless transmitter, eNet SMART HOME App ¹⁾	using eNet wireless transmitter, eNet SMART HOME App ¹⁾
	Display	LED and System 3000 App	LED and System 3000 App	LED and eNet SMART HOME App ¹⁾	LED and eNet SMART HOME App ¹⁾
		using System 3000 App	using System 3000 App		
		with brightness and temperature sensor BT	with brightness and temperature sensor BT	eNet wireless sun sensor Solar	eNet wireless sun sensor Solar
		with brightness and temperature sensor BT	with brightness and temperature sensor BT	eNet wireless sun sensor Solar	eNet wireless sun sensor Solar
		with brightness and temperature sensor BT	with brightness and temperature sensor BT	eNet wireless sun sensor Solar	eNet wireless sun sensor Solar
	X	X	X	X	X
	X				
	X				
				using eNet SMART HOME App ¹⁾	using eNet SMART HOME App ¹⁾
				using eNet SMART HOME App ¹⁾	using eNet SMART HOME App ¹⁾

5.6 Hanging types

Blinds and shutters are grouped under the term “hangings”, and are used both in the commercial and the private sector in a variety of different types.

The dangers of using blind control systems

Some applications can pose a danger to the user. In the case of heavy rolling lattice shutters, for example, there is a risk of injury from pinching fingers or hands. These dangers must be excluded by applying additional suitable safety measures. Measures may include using light barriers or a collision protection system.

Potential applications

The various types of hangings are used as glare and sun protection in the home and office as well as in sun rooms and greenhouses:

- As shutters made of plastic, metal or wood for protecting the home interior
- As a strip curtain in the living room or in meeting rooms
- As an awning on a terrace or balcony
- As rolling lattice shutters on shop windows
- As roller shutters at the entrances of larger halls, such as storage or sales halls and car repair shops











Shading system requirements

Shutters are usually hangings that are raised and lowered by means of a webbing or a crank drive. Alternatively, the systems are equipped with a motorised drive that raises and lowers them.

Gira System 3000 is a modern and convenient system and meets the following requirements:

- It can be used universally for most motorised drives on the market
- The system has one or more operating points or auxiliary units
- The blind control system can be upgraded to system controllers with individual, group and central control
- The system has a central wind alarm. It automatically moves to a safety position and locks itself in place
- It has automatic sun protection and a twilight function
- Operation is manual, timed or controlled wirelessly
- The blind control system has a well-balanced price/performance ratio
- Different insert/top unit combinations provide a variety of functionalities

5.6.1 Selection of the top unit

Operating top unit	
Operating top unit arrow symbols	
Touch top unit	
Operating top unit Memory arrow symbols	
Blind timer and timer Display	
Operating top unit BT	
Blind timer and timer BT	
eNet wireless operating top unit arrow symbols	
eNet wireless operating top unit	
eNet wireless operating top unit Memory arrow symbols	
eNet wireless operating top unit Memory	

The selection of the top unit depends on the type of hanging and the desired range of functions. A total of eleven different types of top units are available.

Types of hangings with and without special requirements

There are different types of hangings with different requirements:

Controllable with all top units:

- Shutters and blinds that only approach the upper and lower end position and the ventilation position
- Awnings that require no fabric stretching function

Can be controlled with the operating top unit BT, blind timer and timer BT or eNet wireless operating top unit

- Awnings that require a fabric stretching function
- Hangings that protect against excessive sunlight and for which a supplementary component, a brightness sensor, is essential
- Hangings with targeted positioning

Depending on the function and application, an eNet server is also required for the eNet wireless operating top units.

Cup anemometer

Generally, the cup anemometer consists of three to four arms on a joint axis with hemispherical cups at each end. The wind sensor for the blind control system consists of two components, the cup anemometer and the evaluation unit. The anemometer is mounted to the roof or the side of the building. Note that the anemometer is mounted in a position favourable for measuring the wind force and not in one that is sheltered from the wind.

5.7 Wind alarm

5.7.2 Wind sensor Standard

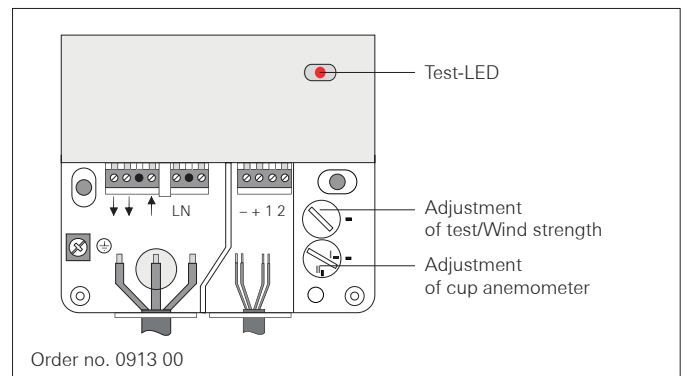
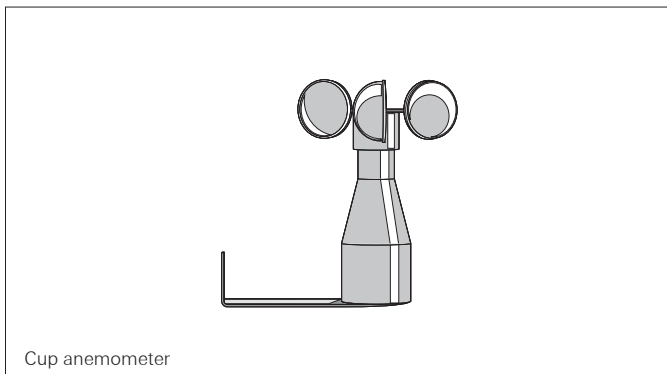

5.7.1 Wind sensor

The wind sensor automatically moves the hangings to a protective position if a predefined wind force threshold is exceeded. The sensitive blind slats or awnings are thus protected from possible destruction by strong winds or storms.

The wind sensor is the operating device of the cup anemometer. Depending on the pre-selected wind speed level, a zero-voltage relay closes in the evaluation unit. A mains voltage of 230 V is connected to auxiliary input 2 of the blind control insert using this relay. If the wind sensor detects an excessively high wind speed, the hangings are automatically raised.

With group or central control, all blinds with an auxiliary input that has been connected to the evaluation unit are firmly locked in the upper end position and cannot be operated, either automatically or manually. Only when the wind speed measured by the wind sensor has fallen below the preset threshold again is the wind alarm deactivated and the blinds can be operated again.

5.7.3 Central wind alarm

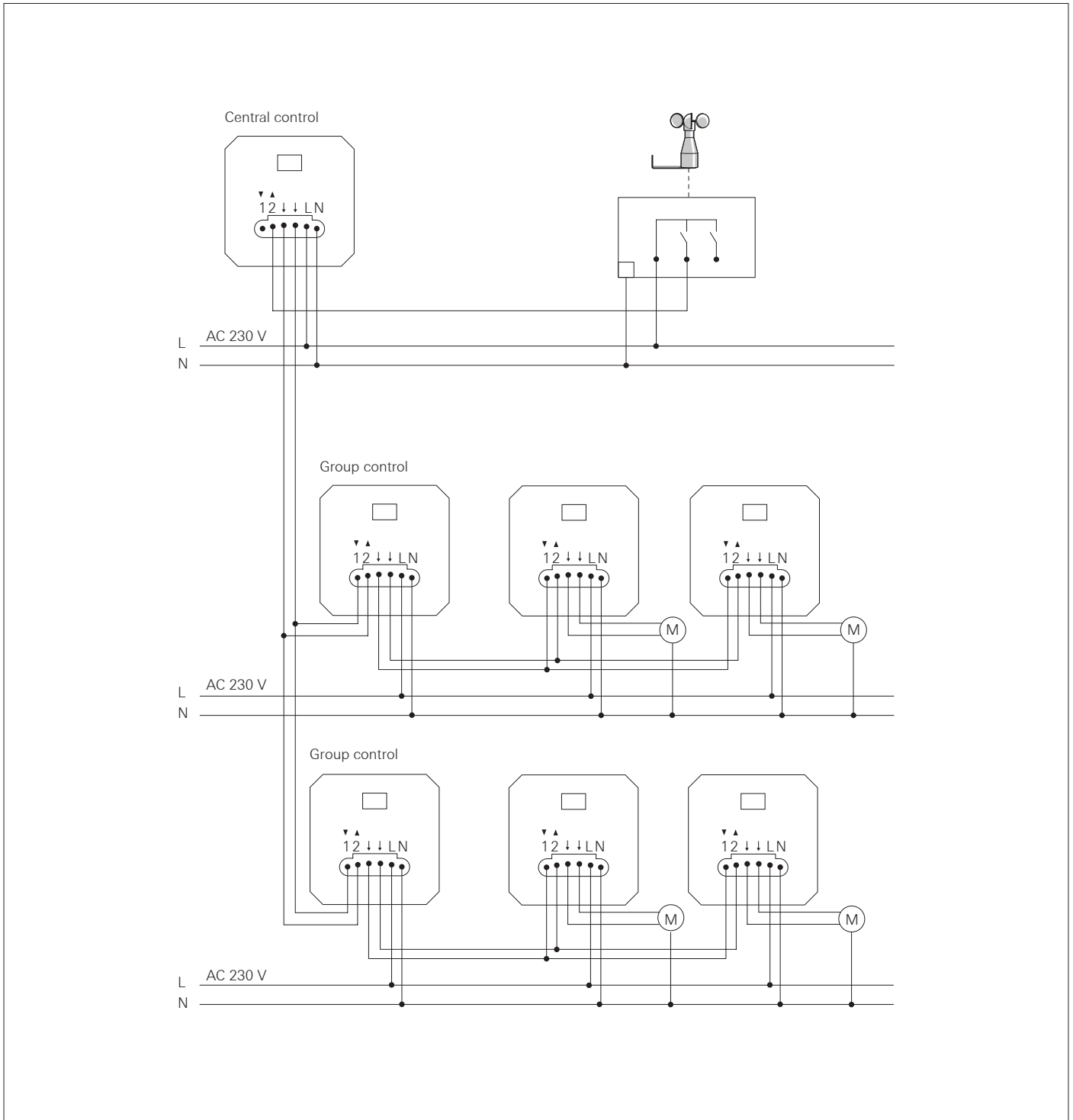

Thanks to the auxiliary unit principle of the System 3000, the anemometer can be used throughout different phases as a central wind alarm for all blinds in an installation.

5.8 Sun protection function

5.8.1 Top units for the sun protection function

You can upgrade your operating top unit BT and blind timer and timer BT individually with the brightness and temperature sensor BT. It is also possible to connect the eNet wireless operating top units to the eNet wireless sun sensor Solar. This turns your blind control insert into a complex, yet easy-to-use control centre for the building's shading system.

General details

You can upgrade the two Bluetooth top units, blind timer and timer BT or operating top unit BT with the brightness and temperature sensor BT. The assignment of the sensor to the Bluetooth top units is carried out by means of the Gira System 3000 App, and can be reversed at any time.

You can assign a brightness and temperature sensor BT to the blind timer and timer BT and to the operating top unit BT.

After assignment, you can call up the current temperature and brightness values with your Gira System 3000 App. The brightness sensor transmits brightness values in the range of 5 to 80,000 lx, while the temperature sensor transmits temperatures in the range of -5 °C to + 55 °C to the Bluetooth top units. As a rule, the current brightness and temperature values are transmitted every 5 minutes. If there are changes in brightness of more than 10 per cent of the current value, these changes are transmitted by the sensor to the Bluetooth top units so that they trigger the shading or twilight function.

Connect the eNet wireless operating top units to the eNet wireless sun sensor Solar. The brightness value (4,000 to 80,000 lx), twilight value (5 to 250 lx) and temperature value (15 to 40°C) can be set directly on the eNet wireless sun sensor Solar. If the actual values exceed or fall below the set values, the corresponding scene (sun protection, sun protection depending on temperature or twilight) will be triggered and the hanging moved to the corresponding position.

Sun protection

Each of the two Bluetooth top units, blind timer and timer BT and operating top unit BT, has a sun protection function that you can activate or deactivate as required. The sun protection function is deactivated by default.

The eNet wireless operating top units are actuated by using the scene function of the eNet wireless sun sensor Solar.

With the Bluetooth top units, you set a threshold for the sun brightness by means of the Gira System 3000 App. With the eNet wireless operating top units, this threshold is adjusted directly on the eNet wireless sun sensor Solar using a dial. In each case, the adjustment range of the threshold is 4,000 to 80,000 lx.

If the specified threshold is exceeded, the hangings are automatically lowered. However, this only happens after a time delay of two minutes to ensure that the level has not only been exceeded because of a temporary light disturbance. Similarly, the hangings are automatically raised if the threshold is not reached. In this case, the time delay is 15 minutes to ensure that the threshold is not affected by temporary cloud fields, for example, causing the hangings to be raised again by mistake.

Twilight

In addition to the sun protection function, each of the two Bluetooth top units, blind timer and timer BT and operating top unit BT, also has a twilight function. This can be turned on or off at dawn and dusk as needed.

The twilight function is deactivated for dawn and dusk by default. As with the sun protection function, the twilight function is triggered on the eNet wireless operating top units by a scene on the eNet wireless sun sensor Solar.

With the Bluetooth top units, you can set a threshold for twilight using the Gira System 3000 App. The adjustment range of the threshold is 5 to 4,000 lx. With the eNet wireless operating top units, this threshold is again set directly on the eNet wireless sun sensor Solar using a dial and the range is 5 to 250 lx.

If the actual value falls below this threshold, the twilight function is carried out with a time delay of four minutes.

When using the twilight function, keep in mind that the sensor cannot detect when dawn arrives if the blinds are completely lowered.

Temperature

You can use the Gira System 3000 App to set a temperature threshold for the Bluetooth top units, blind timer and timer BT and operating top unit BT. The adjustment range of the threshold is 5 to 50 °C and there is also an Off position.

With the eNet wireless operating top units, the threshold is adjusted in the eNet wireless sun sensor Solar. In this case, the adjustment range is 15 to 40 °C.

If the brightness threshold set in the sun protection function and the adjustable temperature threshold are now exceeded, the brightness function is activated. However, if only the brightness threshold is exceeded and the temperature threshold is still within the specified range, the function will not be activated. In this case, the temperature will now be carefully monitored so that the brightness function can be activated immediately when the temperature is exceeded.

Note that the temperature measured on a window pane may differ from the actual room temperature.

The brightness and temperature sensor BT is a battery-powered device and therefore does not require an unsightly line. Using an adhesive pad, it is easy to attach without the use of tools to the inside of a window pane. The brightness and temperature sensor BT has a wireless range of up to ten metres in closed rooms.

5.8.2 Brightness and temperature sensor BT

The sensor detects the brightness and temperature values and sends the current measured values to the two Bluetooth top units, blind timer and timer BT or operating top unit BT. Depending on the actual values detected and the set values, the sun protection or twilight function is activated to move the hangings to a set position or to switch on the lighting.

Temperature-dependent shading is started if the set brightness and temperature values are exceeded. For example, a sun room can be shaded automatically as soon as a pre-defined temperature is exceeded in order to prevent it from overheating. You can make all the settings in the Gira System 3000 App. In addition, you can read all current temperature and brightness values in the app, giving you an overview at any time about whether the levels are within the defined limits or whether a threshold level is about to be exceeded or not reached.

5.8.3 Pairing brightness and temperature sensor BT - or - Pairing sensor

Please note that the brightness and temperature sensor BT does not perform the evaluation of the recorded values. This is still done in the devices assigned using Bluetooth. There is a MAC address on the brightness and temperature sensor BT. The operating top unit BT or the blind timer and timer BT is connected to the brightness and temperature sensor BT by entering the MAC address in the Gira System 3000 App. Each operating top unit BT or blind timer and timer BT can only work together with one sensor. However, one sensor can supply several operating top units BT or blind timer and timers BT with sensor data.

The eNet wireless sun sensor Solar is a solar-powered device, so it has no unsightly line and requires no battery. Using a suction cup, it is easy to attach without the use of tools to the inside of a window pane. You simply need to moisten the suction cup a little, place the sun sensor on the window pane and press it firmly. By using the eNet wireless system, the transmission range is about 100 m in free field.

5.8.4 eNet wireless sun sensor Solar

The sensor detects the brightness and temperature values. Depending on the actual values detected and the values set on the eNet wireless sun sensor Solar, the sun protection or twilight scene is triggered so that the hangings move to a set position or the lighting switches on.

Temperature-dependent shading is only started if the set brightness and temperature values are exceeded. This can be used in colder seasons, above all. Shading of the interior is only triggered if, in addition to the sun protection value, the set temperature value is also exceeded. After sun protection has been triggered, the temperature evaluation is deactivated.

6 // Heating, ventilation, room climate

Automatic room climate control offers great potential for energy savings, especially when retrofitted in buildings with a conventional installation. Thanks to the integration of the heating control into System 3000, it is now also convenient and easy to programme and operate using the Gira System 3000 App.

6.1 Device overview

Top units	Order no.
System 3000 room temperature controller Display	5393 ..
System 3000 room temperature controller BT	5394 ..

Inserts	Order no.
System 3000 relay switching insert	5403 00
System 3000 electronic switching insert	5405 00
System 3000 room temperature controller insert with sensor connection	5395 00

Sensor	Order no.
System 3000 brightness and temperature sensor BT	5466 02
Remote sensor	1493 00

Accessories	Order no.
Thermal servo 230 V~	2169 00

System 3000 relay switching insert

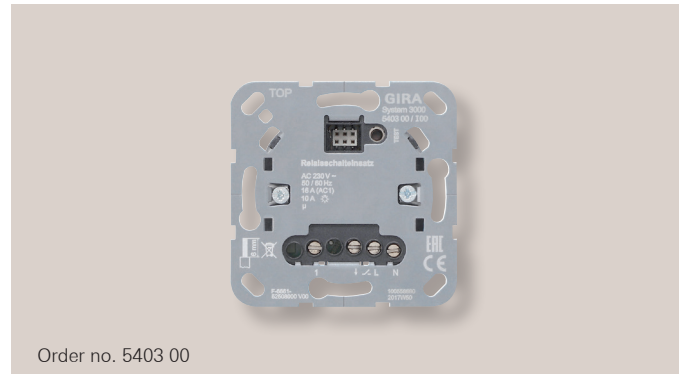

The relay switching insert switches different light sources such as LEDs, halogen light bulbs or fluorescent lamps and motors. In combination with a room temperature controller top unit, it can control electric floor heating systems and electrothermal servos. The TEST button with LED display can be used to conveniently set delay times if desired.

The switching insert can be installed in a commercially available device box (e.g. Kaiser 1055-02) in accordance with DIN 49073.

Functions at a glance:

- Delay times can be set when an operating top unit is used
- Auxiliary input for rocker button, 2 or 3-wire auxiliary insert
- When used as a room temperature controller insert, the auxiliary input is used to switch over to cooling mode.
- Suitable for switching the following loads per channel:
 - typ. 400 W HV LED lamps
 - typ. 500 W compact fluorescent lamp
 - 2,300 W light bulbs
 - 2,300 W HV halogen lamps
 - 1,200 VA fluorescent lamps, not compensated
 - 1,500 W Gira Tronic transformers
 - 1,000 VA wound transformer
 - 6 A switching current for motors
- Functions that can be set using the TEST button:
 - Switching on and off using short operation
 - Delay time: None, 1 min, 5 min, 30 min, 60 min
- AC 230 V, 50/60 Hz
- VDE mark
- Screw terminals

System 3000 electronic switching insert

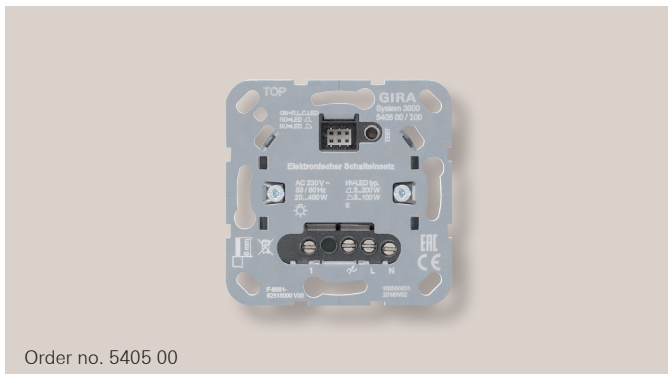

The electronic switching insert can be operated with or without neutral conductor.

In the event of operation with a neutral conductor, the electronic switching insert is supplied via the external conductor and neutral conductor, and therefore there is no leading or trailing edge. It is not necessary to set an operating mode. The electronic switching insert switches light bulbs, HV halogen lamps, electronic or inductive transformers with halogen or LED lights as well as switchable or dimmable HV LED or compact fluorescent lamps. Control of electrothermal servos in combination with a room temperature controller top unit is possible.

In the event of operation without a neutral conductor, the electronic switching insert is supplied via the external conductor and the connected load, and therefore there is no leading or trailing edge. The corresponding operating mode is set automatically or manually to match the load. The set operating mode is indicated by an LED. The electronic switching insert switches light bulbs, HV halogen lamps, electronic or inductive transformers with halogen or LED lights as well as switchable or dimmable HV LED or compact fluorescent lamps.

The electronic switching insert can be installed in a commercially available device box (e.g. Kaiser 1055-02) in accordance with DIN 49073.

Functions at a glance:

- Switch-on with soft start, which preserves the life of the lamp
- Auxiliary input for rocker button, 2 or 3-wire auxiliary insert
- Electronic short circuit protection with permanent deactivation after seven seconds at the latest, reversible
- Electronic excess-temperature protection
- Suitable for switching the following loads:
 - typ. 3 to 100 W HV LED lamps
 - typ. 3 up to 100 W compact fluorescent lamp
 - 20 to 400 W light bulbs
 - 20 to 400 W HV halogen lights
 - 20 to 400 W Gira Tronic transformer
 - typ. 20 to 100 W electronic transformer with LV LED
 - 20 to 400 VA wound transformer
 - typ. 20 to 100 VA wound transformer with LV LED
 - In Trailing Edge Connected Load operating mode for HV LED lamps typ. 3 to 200 W, electronic transformers with LV LED typ. 20 to 200 W
 - 1 to 10 number of thermal servos (order no.: 2169 00)
- AC 230 V, 50/60 Hz
- VDE mark
- Screw terminals

System 3000 room temperature controller insert with sensor connection

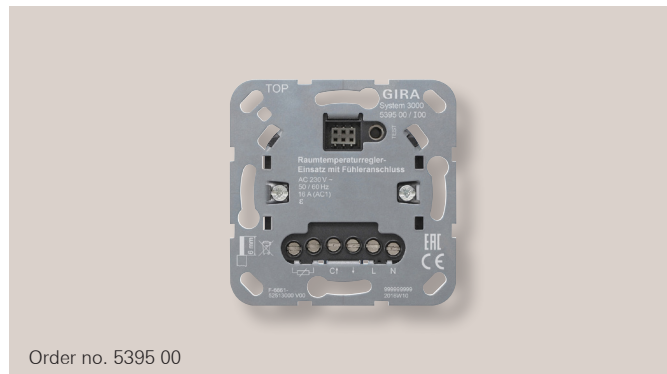

The room temperature controller insert with sensor connection is suitable for switching electric floor heating systems or electrothermal servos. In combination with the room temperature controller Display or room temperature controller BT, a comfortable temperature control can be implemented.

Modern heat pump heating systems often enable rooms to be cooled, too. The room temperature controller insert has an input for switching to cooling mode.

Functions at a glance:

- Recommended mounting height 1.50 m.
- Temperature control using pulse width modulation (PWM) or two-point control (On/Off)
- Allows connection of a remote sensor (accessory)
- AC 230 V, 50/60 Hz
- 10 mA to 16 A (AC1) switching current
- max. 3600 W connected load
- VDE mark
- Screw terminals

System 3000 room temperature controller Display



The room temperature controller Display enables manual and time-controlled regulation of the room temperature. It consists of a capacitive touch surface in the typical Gira design with an illuminated display. Operation on a room temperature controller insert, relay switching insert or electronic switching insert from System 3000.

Functions at a glance:

- Current time can be saved as switching time, quick programming
- Automatic summer/winter time switchover, deactivatable
- Timer with three memory areas. For each memory area comfort and lowering time for Mon – Fri and Sat + Sun
- Setting of a comfort, reduction, cooling or frost protection temperature
- Controller output: Pulse width modulation (PWM) or 2-point control
- Heating optimisation (the temperature is reached at the set time)
- Adaptation to valves (de-energized open or de-energized closed)
- Activation of cooling mode via the insert
- Supports internal and external temperature sensors
- Temperature drop detection (calls up the frost protection temperature when the window is open)
- Operation lock, prevents unintentional operation
- Valve protection function (opening and closing of the valve once a week)
- Display switches off after 2 minutes, permanent display of the current time is possible

System 3000 room temperature controller BT



The room temperature controller BT enables manual and time-controlled regulation of the room temperature. It consists of a capacitive touch surface in the typical Gira design with an illuminated display. Operation on room temperature controller insert, relay switching insert or electronic switching insert from the System 3000. You can operate and program it conveniently using your smartphone and the Gira System 3000 App via Bluetooth.

Functions at a glance:

- Current time can be saved as switching time, quick programming
- Automatic summer/winter time switchover, deactivatable
- Timer with three memory areas. For each memory area comfort and lowering time for Mon – Fri and Sat + Sun
- Setting of a comfort, reduction, cooling or frost protection temperature
- Controller output: Pulse width modulation (PWM) or 2-point control
- Heating optimisation (the temperature is reached at the set time)
- Adaptation to valves (de-energised open or de-energised closed)
- Activation of cooling mode via the insert
- Supports internal and external temperature sensors
- Temperature drop detection (calls up the frost protection temperature when the window is open)
- Operation lock, prevents unintentional operation
- Valve protection function (opening and closing of the valve once a week)
- Display switches off after 2 minutes, permanent display of the current time is possible

Functions with Gira System 3000 App:

- Weekly timer with 40 individually programmable switching points and temperatures
- Holiday mode (start, end, temperature)
- Boost function: Rapid heating up for 5 minutes max.
- Blocking of on-site operation possible
- Integration of an external temperature sensor via Bluetooth
- Minimum and maximum temperature values can be set
- Settings and time programs can be copied to other top units

System 3000 brightness and temperature sensor BT

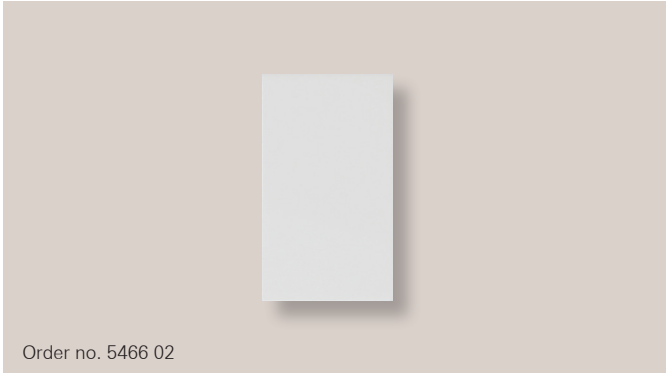

The brightness and temperature sensor BT is used to record brightness and temperature levels. It can be affixed anywhere without tools using an adhesive pad and is powered by a lithium battery. As a result, it is independent of the mains power supply and can be attached anywhere without unsightly lines.

The wireless range in a room is about ten metres.

Functions at a glance:

- Use as a room temperature sensor instead of the internal room temperature sensor in the BT room temperature controller
- Temperature is measured once a minute
- Transmits the temperature value every 5 minutes
- Sends the current temperature value if the temperature changes by more than 0.2 K
- Reports low battery level

System 3000 remote sensor



Remote sensor for connection as external temperature sensor to a room temperature controller insert with sensor connection.

Remote sensor with 4 m supply cable (2 x 0.5 mm²), can be extended to 50 m.

Sensor in plastic cap with 7.8 mm diameter and 20 mm length.

6.2 Application scenarios for room temperature control

6.2.1 Floor heating, hydronic, without temperature limitation

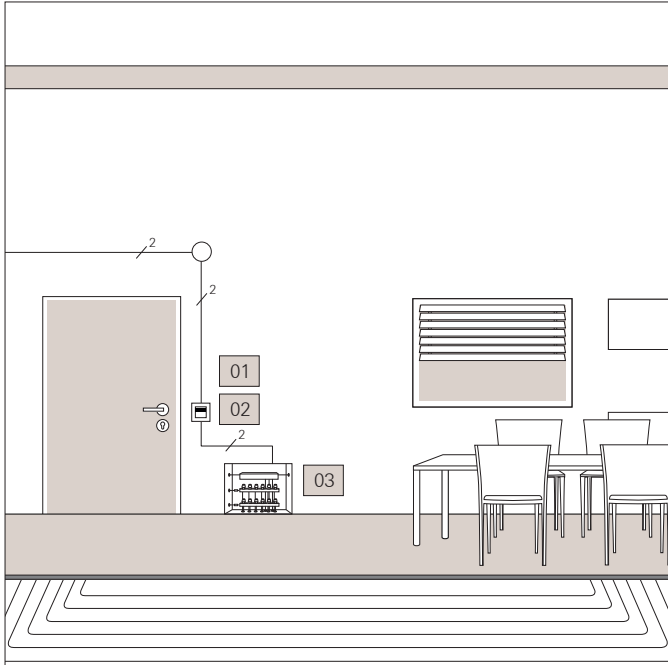

- Temperature measurement in the room temperature controller
- Output of the electronic switching insert controls a thermal servo
- "Room" setting in the room temperature controller. The room temperature is measured using the internal temperature sensor.

6.2.2 Floor heating, hydronic, with temperature limitation

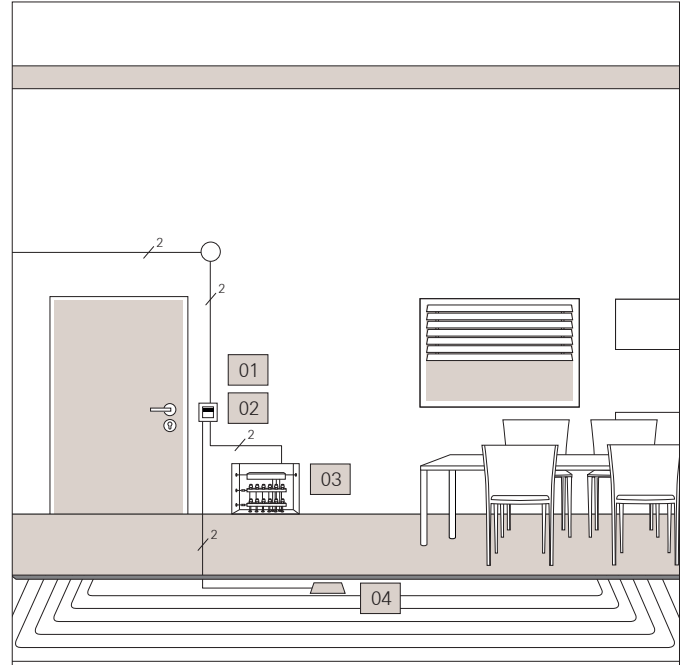

- Temperature measurement in the room temperature controller
- Temperature measurement in the floor (screed) by the room temperature controller insert to limit the max. surface temperature
- Output of the room temperature controller insert controls a thermal servo
- "Room & floor" setting in the room temperature controller. The room temperature is measured by the internal temperature sensor and the floor temperature is measured by the remote sensor.

Number	Components	Quantity	Order no.
01	Electronic switching insert	1	5405 00
02	Room temperature controller Display	1	5395 ..
03	Thermal servo 230 V~	1	2169 00

Number	Components	Quantity	Order no.
01	Room temperature controller insert with sensor connection	1	5395 00
02	Room temperature controller Display	1	5395 ..
03	Thermal servo 230 V~	1	2169 00
04	Remote sensor	1	1493 00

6.2.3 Floor heating, electric, without temperature limitation

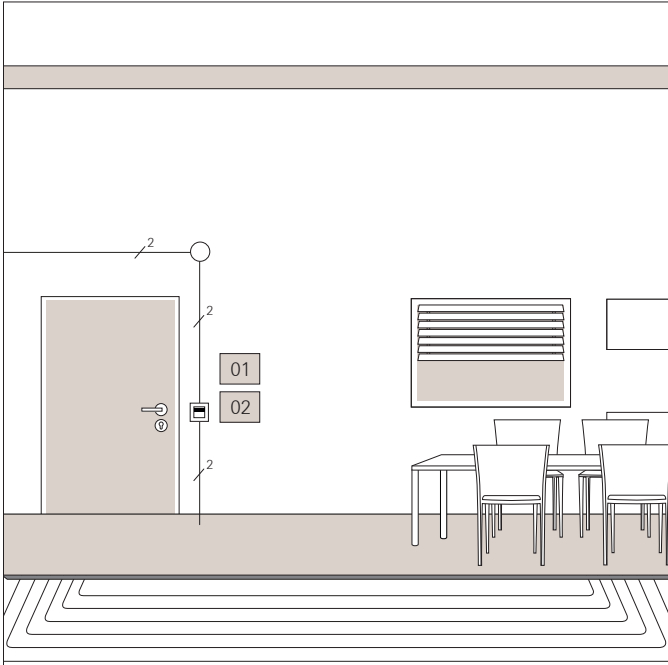

- Temperature measurement in the room temperature controller
- Output of the relay switching insert directly controls the electric heating system
- "Room" setting in the room temperature controller. The room temperature is measured using the internal temperature sensor.
- Temperature measurement in the room temperature controller

6.2.4 Floor heating, electric, with temperature limitation

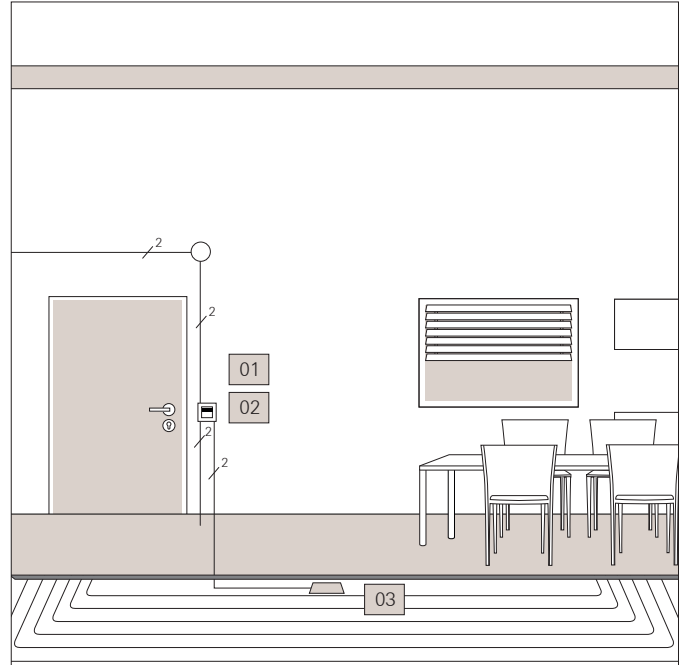

- Temperature measurement in the floor (screed) by the room temperature controller insert to limit the max. surface temperature
- Output of the room temperature controller insert directly controls the electric heating system
- "Room & floor" setting in the room temperature controller. The room temperature is measured by the internal temperature sensor and the floor temperature is measured by the remote sensor.

Number	Components	Quantity	Order no.
01	Relay switching insert	1	5403 00
02	Room temperature controller Display	1	5395 ..

Number	Components	Quantity	Order no.
01	Room temperature controller insert with sensor connection	1	5395 00
02	Room temperature controller Display	1	5395 ..
03	Remote sensor	1	1493 00

6.2.5 Floor temperature control

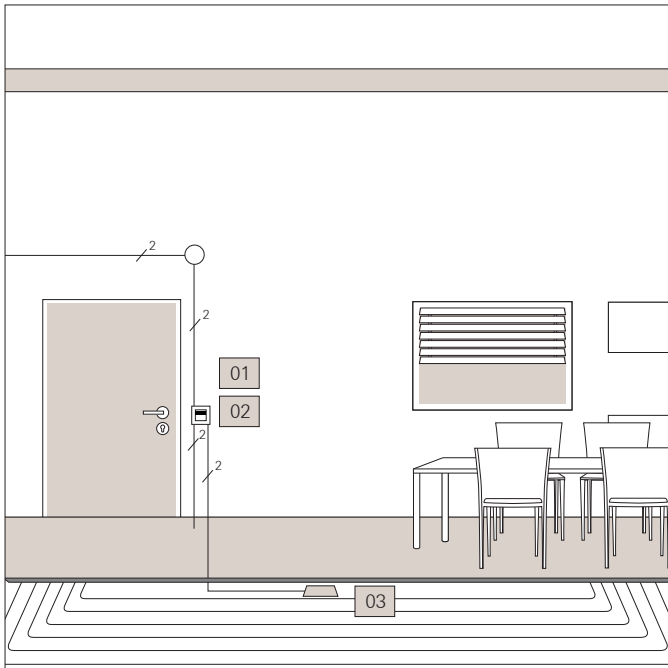

- Typ. electric floor heating, limitation of max. surface temperature as temperature control
- Temperature measurement in the floor (screed) by the room temperature controller insert to limit the max. surface temperature
- Output of the room temperature controller insert directly controls the electric heating system
- Radiator heating system heats the room and is not controlled by the room temperature controller
- "Floor" setting in the room temperature controller. The room temperature is measured by the remote sensor. The internal temperature sensor is deactivated.

Number	Components	Quantity	Order no.
01	Room temperature controller insert with sensor connection	1	5395 00
02	Room temperature controller Display	1	5395 ..
03	Remote sensor	1	1493 00

6.2.6 Temperature detection with external brightness and temperature sensor BT

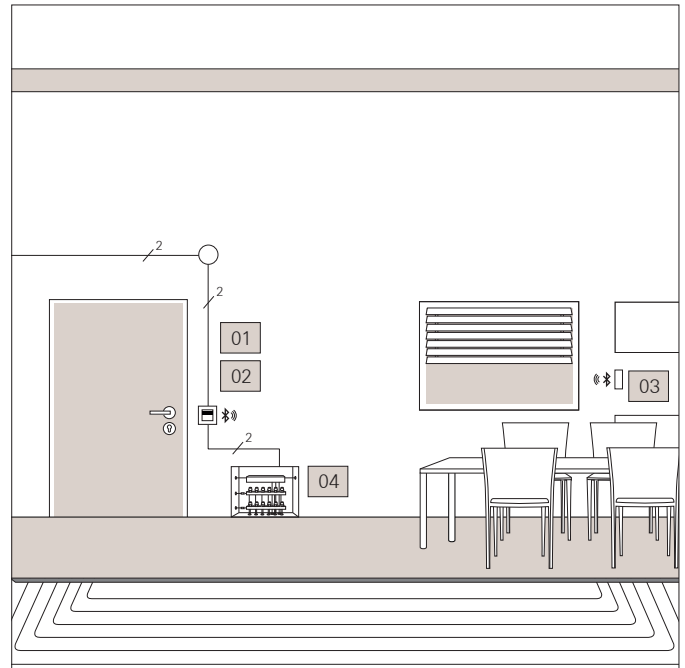

- External temperature measurement in the brightness and temperature sensor BT
- The BT room temperature controller handles the temperature control
- Output of the insert controls a thermal servo
- Output of the room temperature controller insert controls a thermal servo
- "Room" setting in the room temperature controller. The room temperature is measured by the BT brightness and temperature sensor.

Number	Components	Quantity	Order no.
01	Room temperature controller insert with sensor connection	1	5395 00
02	Room temperature controller BT	1	5394 ..
03	Brightness and temperature sensor BT		5466 02
04	Thermal servo 230 V~	1	2169 00

6.3 Electrical connection

6.3.1 Connecting the insert

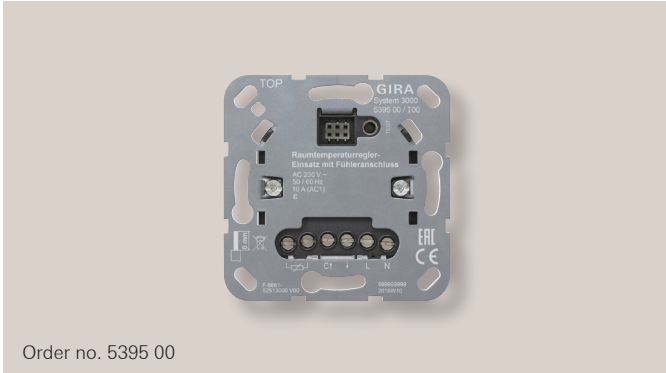

The room temperature controller insert with sensor connection has six L and N terminals for the power supply, output \downarrow for connecting an electric floor heating system or electrothermal servo, input C \uparrow for switching to cooling mode and two terminals $\text{---} \diagup \diagdown$ for connecting a remote sensor for external temperature measurement.

The room temperature controller insert works exclusively with room temperature controller top units. Other System 3000 top units will not function.

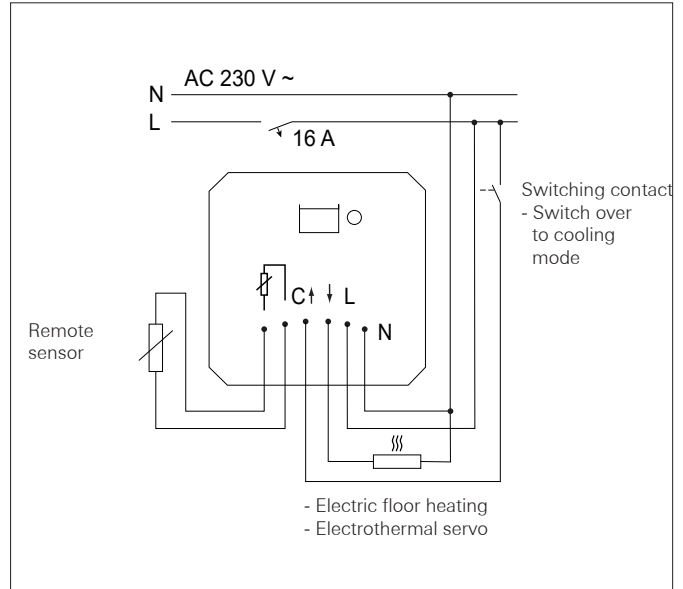

1. Connect the room temperature controller insert according to the connection diagram.
2. Mount the room temperature controller insert in a device box. The connection terminals must face downwards. Thanks to its small installation depth of only 24 mm, there is enough connection space.
3. Switch on the mains voltage.
4. You can use the TEST button to switch the connected load even without a top unit. The LED lights up when the load is switched on.
5. Finally, mount the cover frame and the top unit in a de-energised state.

Note:
If a mains voltage AC 230 V is applied to input C \uparrow , cooling mode is active

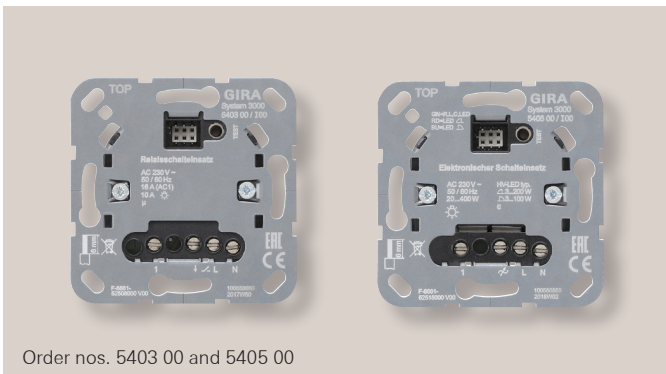

Four terminals are available for the two switching inserts, the relay switching insert and the electronic switching insert. It is not possible to connect an external remote sensor.

Terminals L and N are used for power supply, output \downarrow or $\text{---} \diagup \diagdown$ for connecting an electric floor heating system or electrothermal servo, and input 1 for switching to cooling mode.

6.4 Functional description

Heating and cooling operating mode

Modern heat pump heating systems often enable rooms to be cooled, too. The room temperature controller top units support this function with the "Heating and cooling" operating mode. In this operating mode, the set cooling temperature is maintained. There are no time programs in cooling mode. The cooling temperature can only be changed using the temperature parameters and not by using the +/- buttons.

In combination with a room temperature controller insert, cooling mode is activated by applying the mains voltage to input terminal C \uparrow . With switching inserts, cooling mode is activated by applying the mains voltage to auxiliary input 1.

Note:

If you have a heat pump heating system where you can only activate cooling mode manually or you do not have the corresponding supply cable, it is possible to activate cooling mode on the insert with the room temperature controller BT. To do this, you must place a wire jumper between the external conductor L and the cooling input C \uparrow or auxiliary input 1. You can use the System 3000 App to activate or deactivate the cooling mode at the same time as the switchover on your heat pump heating system.

Frost protection/temperature drop detection

The frost protection temperature is the minimum temperature that is maintained in order to prevent frost damage. In the event of a sharp drop in temperature, for example after a window has been opened, the frost protection temperature is maintained for a maximum of 30 minutes. For this, the temperature drop detection parameter must be activated.

Heating optimisation

Heating is started a maximum of 4 hours before the switching time so that when the switching time is reached, the desired temperature has been achieved and the heating is not just starting. During the heating up phase, the \odot symbol flashes in the display.

Offset -/+

If it is determined that the actual temperature indicated is different to the overall room temperature, a correction value can be entered using this parameter. The actual temperature is then corrected by this offset value.

Controller adjustment

The control principle should be set depending on the heating system and the insert used.

Two-point control (2P):

The output remains switched on until the set target temperature has been exceeded by 0.5 °C. The output is not switched on again until the temperature has fallen to 0.5 °C below the setpoint. Since most heating systems are very sluggish, this control may cause the temperature to overshoot the setpoint.

Pulse width-modulated control (PWM):

Optimised for electrothermal servos such as thermal servo 230 V~, order no. 2169 00. The output is not activated permanently, but for a time that is dependent on the temperature difference between target and actual temperature (pulse width). Using this method, the actual temperature comes closer and closer to the target temperature.

Valve adjustment

This parameter is used to adjust to the electrothermal servos used. There are drives that are open (de-energised open, setting NO) or closed (de-energised closed, setting NC) when there is no supply voltage.

Temperature sensor

The room temperature controller top units have a built-in temperature sensor that is used to measure the room temperature. With the room temperature controller BT, a brightness and temperature sensor BT can be integrated using the Gira System 3000 App. In this case, the internal sensor is deactivated.

In conjunction with a room temperature controller insert, a remote sensor can be connected, either to measure the room temperature or to limit the maximum floor temperature.

The following settings are possible.

Setting	Function
Room	The room temperature is measured by the internal temperature sensor or the brightness and temperature sensor BT.
Floor	The room temperature is measured by the remote sensor. The internal temperature sensor is deactivated.
Room and floor	The room temperature is measured by the internal temperature sensor and the floor temperature is measured by the remote sensor in order to monitor the floor temperature. If the maximum floor temperature is exceeded, the floor heating system is switched off until the temperature has fallen below this again.

6.4.1 Overview of programming menu and button combinations

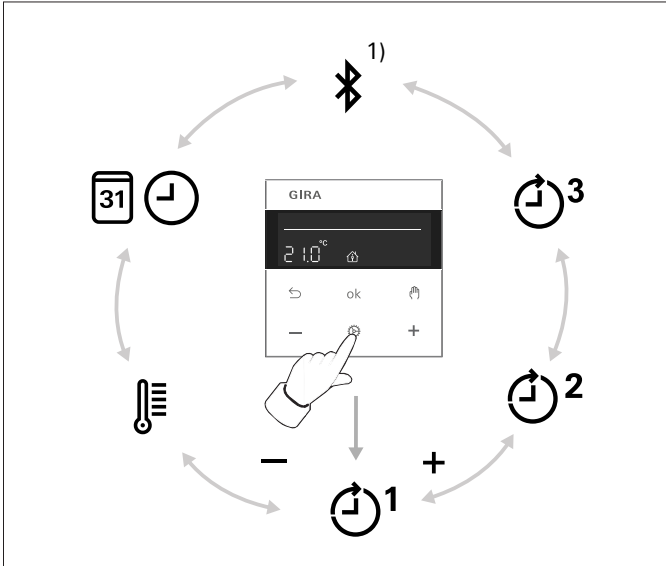

To access or exit the programming menu, press the button. Use - or + to navigate through the menu and confirm the selection with the **ok** button.

Buttons	Function
	Three memory areas for comfort and lowering temperature for the two weekday blocks Mon – Fri and Sat – Sun
	Activate Bluetooth pairing mode for room temperature controller BT
	Set the date, time and the automatic summer time changeover
	Set the comfort temperature, lowering temperature and cooling temperature; activate heating optimisation; temperature drop detection; set an offset value

Button combination	Duration of pressure on button	What is displayed	What happens
- and	More than one second	is displayed or hidden	Button lock is activated or deactivated
and	More than 10 seconds	Countdown from 9 to 0	Parameters for control can be changed
ok and - or +	More than one second	SAVE	Current time is saved as switching time
ok and	More than 10 seconds	Countdown from 9 to 0	Display: Switching between target temperature, actual temperature and current time
ok and	More than 10 seconds	Countdown from 9 to 0	Display: Switching between display permanently on and switch-off after 2 minutes
and	More than 10 seconds	Countdown from 9 to 0	Default setting of the device is restored
+ and -	More than 4 seconds	Err	Disabling of the lock when the top unit or insert is changed

7 // Gira System 3000 App

With the Gira System 3000 App, you can conveniently control System 3000 Bluetooth devices with your mobile end device, such as a smartphone. The Bluetooth connection is established over a range of up to ten metres between the smartphone and the selected System 3000 device. The app allows for convenient

- operation of device functions
- display of levels and states
- creation of time controls and
- configuration of the device.

The app also makes start-up of the device much easier, as device configurations can be easily created, transferred from device to device, and imported from other installations.

If updates are available for the app, they are automatically offered for download from the iTunes App Store (iOS) or the Google Play Store (Android). The software of the Bluetooth devices (firmware) can also be updated through the app. This ensures that the app and device remain up to date at all times.



7.1 Structure of the user interface

Differences in the views

The illustrations in the tile or detailed views may differ from the views in your project. Different operating and control options are available depending on the combination of insert and top unit. Accordingly, this document makes reference only to the basic functions.

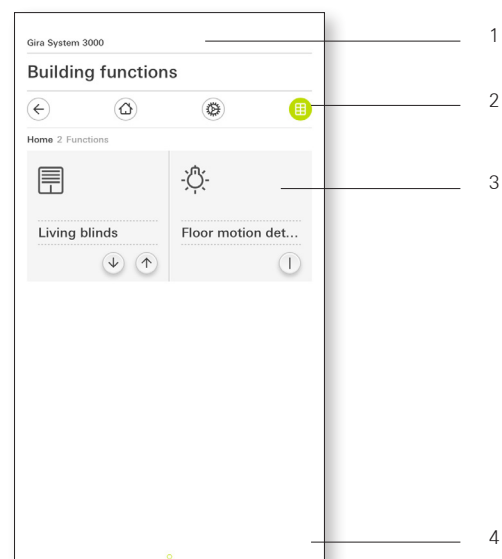

The user interface is divided into four areas:

- 1 The status bar
- 2 Navigation bar
- 3 The action area
- 4 The orientation guide

At the lower edge of the screen you will see a circle for every available function or page. The circle marked shows the current position. By swiping horizontally, you can change the function or page. This also causes the marked circle to shift.

7.2 Navigation bar

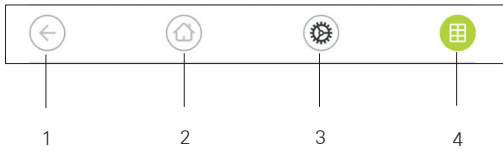

The buttons in the navigation bar have the following functions:

1	Back	Opens the page previously opened
2	Home	Opens the homepage of the action area
3	System	Opens the [Settings] view
4	Change view	Switches between the tile and the detailed view

7.3 Action area

The action area is the central workspace through which you can operate and adjust the settings of the System 3000 Bluetooth devices. You can operate all devices here.

The action area has two view options:

- Tile view
- Detailed view

The first page of the action area is the Home page.

7.3.1 Tile view

Tile view is one of the two view options for the action area, along with detailed view.

In tile view, up to six small tiles can be displayed per page.

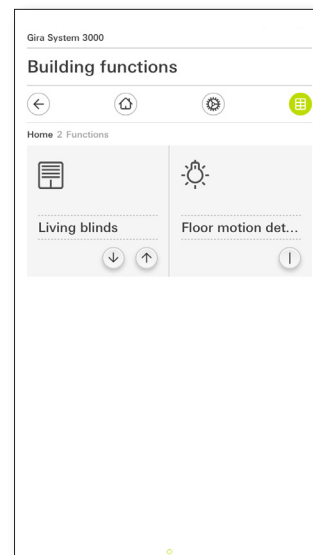

Operation in tile view

Central functions such as switching on and off, raising or lowering the blinds or dimming in fixed steps can be operated directly in tile view. To do so, tap the plus/minus or arrow buttons to dim the light or move the blinds/shutters.

When you tap a tile, the detailed view of the function opens. There (depending on the configuration) you can carry out additional operations in the function.

Note:

Bluetooth connection in tile view

When operated in tile view, a Bluetooth connection must first be set up with the device before an action is carried out. You will recognise this by a delayed response to your operation.

7.3.2 Detailed view

Detailed view is one of the two view options of the action area, along with tile view. Detailed view is opened by tapping a tile in tile view. All operating elements of the respective function are then available on the entire display.

Operation for most functions is by tapping, with some functions, such as the blind control, distinguishing between a short and long press of the button. The following sections deal with some special features of operation.

You can switch from one function to the next by making a horizontal swiping motion with your finger.

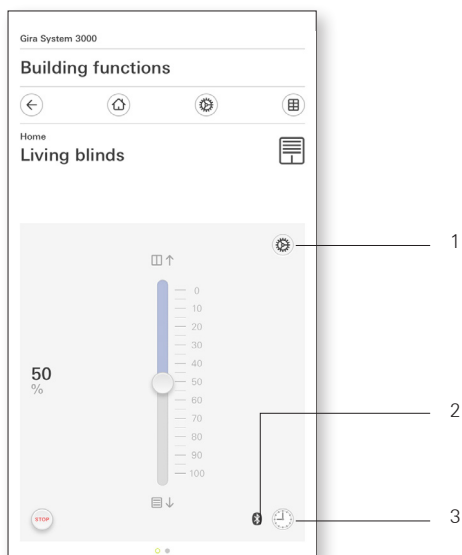

The symbols in the detailed view have the following meanings:

- 1 Set device parameters
- 2 Bluetooth connection active
- 3 Timer (device-dependent)

Adjustable scale

The adjustable scale can be used in the dimmer function. To adjust the brightness, tap directly on the desired value in the scale or drag the adjustable scale to the desired position.

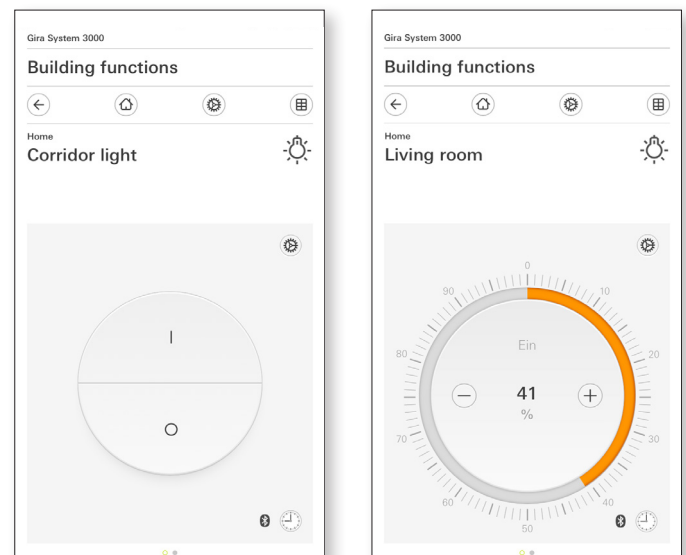

Note:

Bluetooth connection – detailed view

If you switch to detailed view, a Bluetooth connection with the device is already set up in the background. This is indicated by the blue LED that lights up. The functions are therefore carried out without a noticeable delay.

Blind/shutters**Operation using controller**

You can control blinds or shutters in the detailed view using the slider or rocker. To raise or lower the blinds or shutters or to adjust the slats, slide the respective controller to the desired position.

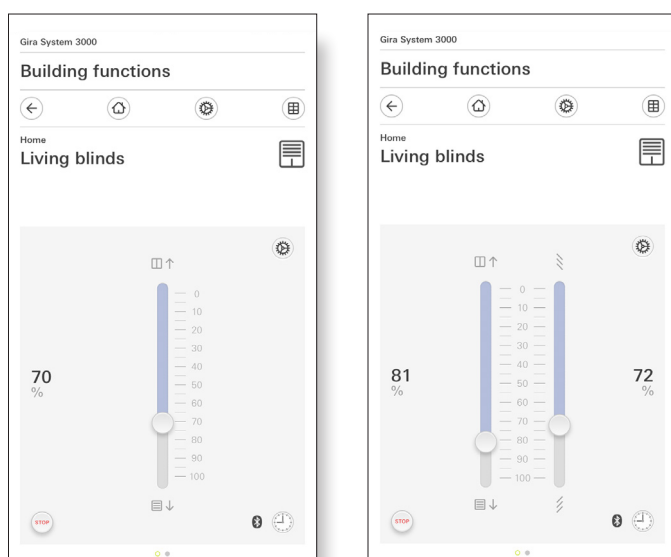
**Stop button**

When you tap the STOP button, you can directly stop active movement by the hanging or a slat adjustment. The hanging then stops immediately at its current position.

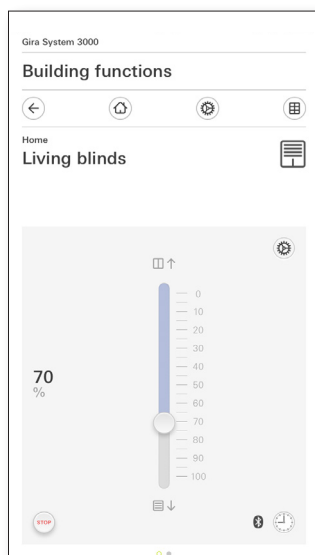
**7.4 Settings in the system menu**

Basic settings can be made in the system menu.

Open the system menu by tapping on the gearwheel icon in the navigation bar.

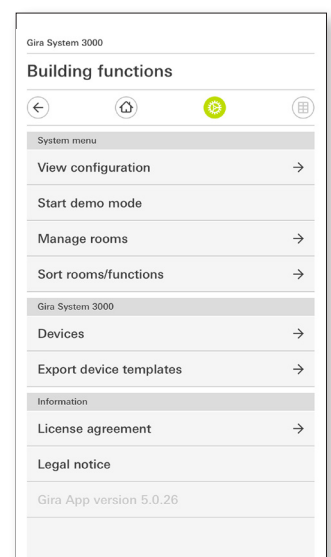

The following functions are available in the system menu:

- View Configuration (see Section 7.4.1)
- Start demo mode
- Manage rooms
- Sort rooms/functions
- Devices (see Section 7.5)
- Export device templates
- Licence agreement

7.4.1 View Configuration

In View Configuration, you can define the functions displayed and the order of the functions for the action area.

Tap the View Configuration button.
The View Configuration page opens.

The following menu item is available: Select Home (see Section 7.4.2)

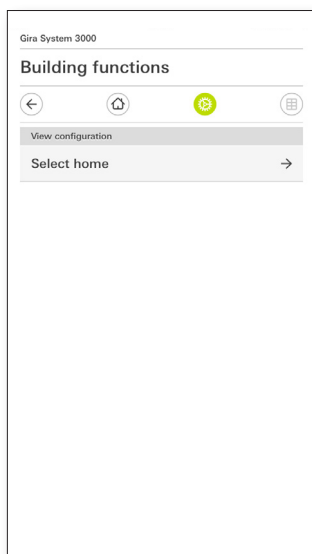

7.4.2 Select Home

Here, you can define whether the Home view is displayed in the tile or detailed view when the Home button is tapped.

- 1 Select the desired view for the Home view.
- 2 Tap the OK button.

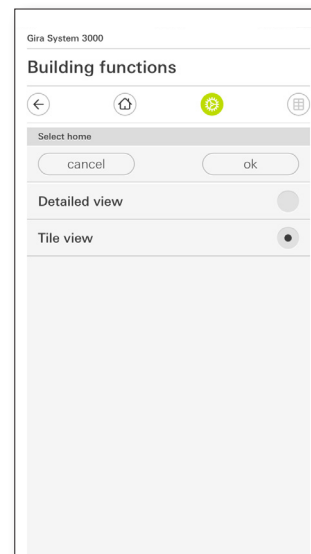

7.5 Devices

Pairing new devices with your Gira System 3000 App.

The following options are available:

- Pair devices (see 7.5.1)
- Unpair devices (see 7.5.2)
- Change the device sequence

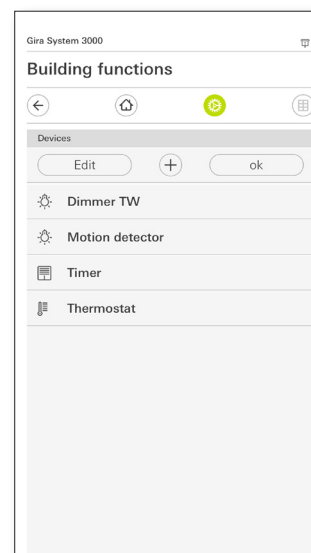

7.5.1 Pairing devices

You can pair new devices with your Gira System 3000 App here.

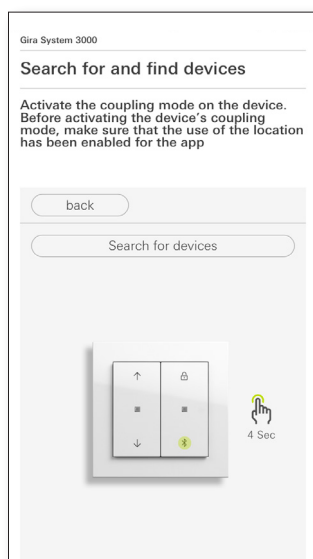

- 1 Tap [+].
- 2 Activate pairing mode on the device.
The blue LED on the device will flash slowly.
Pairing mode is active for one minute.
- 3 Tap [Discover devices] in the app.
Pairing mode automatically closes after successful pairing.
The blue LED lights up to confirm that the connection is active.
- 4 Set the corresponding device parameters.

Note:

Pairing a mobile end device via Bluetooth

You can pair up to eight mobile end devices with a top unit. When pairing the ninth device, the device that has been inactive the longest is deleted.

In the case of blinds, shutters or awnings, a reference movement is carried out into the upper end position after programming. You should not stop this reference movement.

7.5.2 Unpairing devices

You can unpair devices from your Gira System 3000 App here.

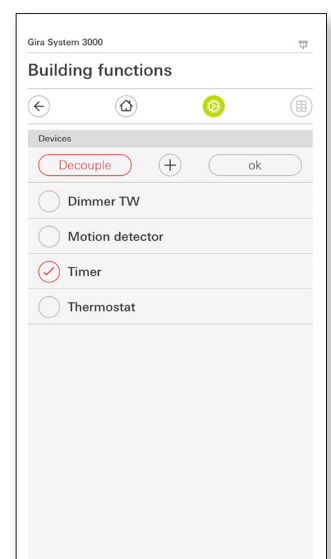
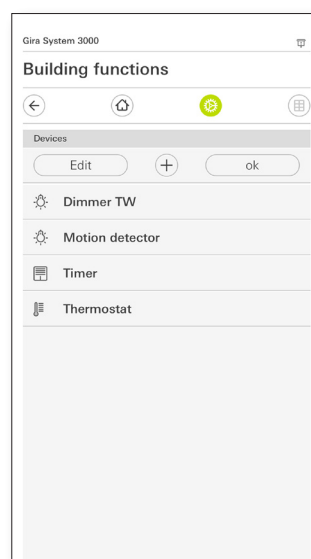

- 1 Tap the [Edit] button.
A selection point appears in front of the devices.
- 2 Select the device to unpair.
A red tick confirms your selection.
- 3 Tap [Unpair].
The device is now removed from the list.
- 4 You should also remove the device from the Bluetooth system menu on your smartphone or tablet.

7.5.3 Assigning a coupling PIN

Assign a pairing PIN so that not just anyone can connect to this device.

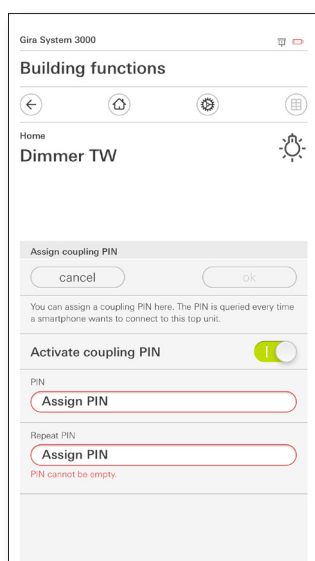

- 1 Tap the [Set device parameters] button in the detailed view.
The [Set device parameters overview] page will open.
- 2 Tap the [Assign pairing PIN] button.
The [Assign pairing PIN] page will open.
- 3 Activate the pairing PIN.
- 4 Enter a 6-digit code.
- 5 Enter the code again.
- 6 Tap [OK] and exit the menu.
To pair this device now, you will need the pairing PIN.

7.5.4 Assigning a device PIN

Assign a device PIN so that only certain people can change the device parameters.

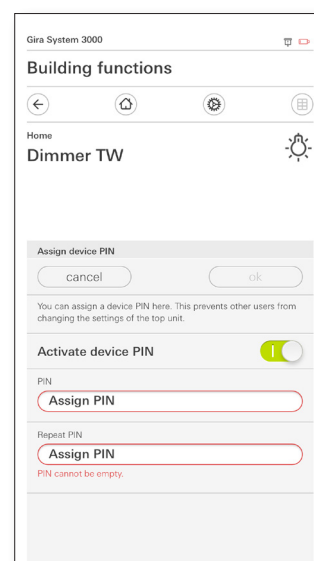

- 1 Tap the [Set device parameters] button in the detailed view.
The [Set device parameters overview] page will open.
- 2 Tap the [Assign device PIN] button.
The [Assign device PIN] page will open.
- 3 Activate the device PIN.
- 4 Enter a 6-digit code.
- 5 Enter the code again.
- 6 Tap [OK] and exit the menu.
To change the device parameters now, you need the device PIN.

7.5.5 Lost PIN number

If you lose the PIN number, regardless of whether it is the pairing PIN or the device PIN, you must reset the device to its default settings. All device parameters will be reset and the timers deleted. After resetting to default settings, the device must be removed from the Gira System 3000 App.

The device must also be removed from the list of paired Bluetooth devices (Settings/Bluetooth) when iOS end devices are used. Otherwise, a new pairing process is not possible.

8 // Operation

8.1 Manual control

Lighting and shading can be controlled simply and intuitively at the touch of a button with the operating top unit, operating top unit Memory, or eNet wireless operating top unit Memory. For programmed control, the blind timer and timer Display, operating top unit BT and blind timer and timer BT are available.

8.1.1 Operating top unit

With the operating top unit, you can control lighting and shading manually at the push of a button. The button reacts over the entire surface and makes switching lights via toggle function particularly easy: pressing the button anywhere turns the light on, and pressing it again switches it off.

This allows you to operate the operating top unit with your elbow as well if you don't have a hand free. In combination with a dimming insert, the lighting can also be dimmed. Pressing and holding the upper half of the button makes the lighting brighter, and pressing and holding the lower half makes it darker. The shading is also controlled by pressing and holding the button: pressing and holding the upper half causes the blind to be raised, while pressing and holding the lower half lowers it again. Once you have defined a ventilation position, the hanging first stops at this position and then after pressing and holding the button, it lowers to the set lower end position.

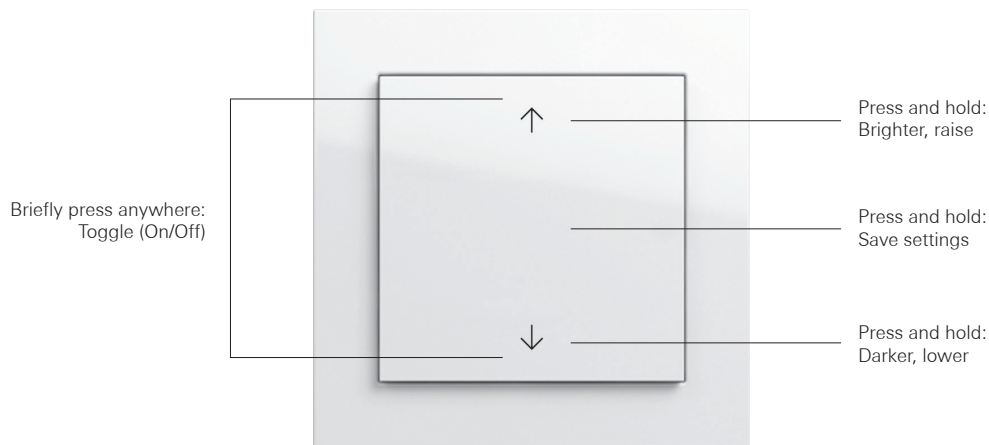

Gira operating top unit with arrow symbols

The operating top unit is also available without arrow symbols.

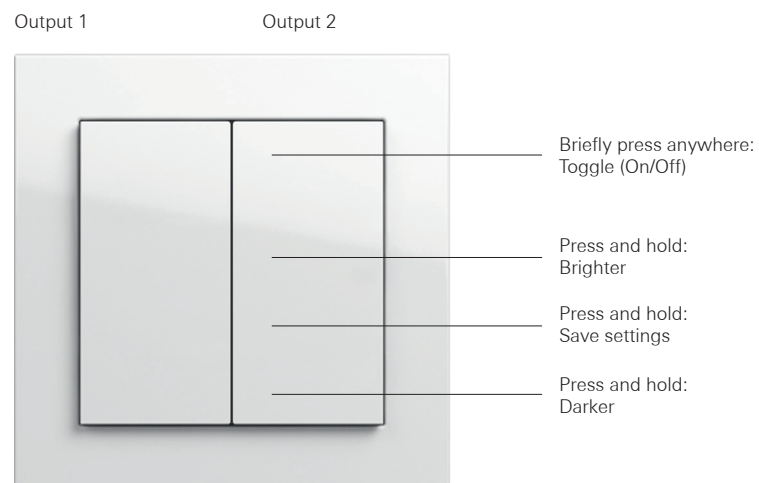

Gira operating top unit, 2-gang

You would like to ...	Implementation	Further information
... switch on the light.	Press the control button briefly.	If the dimming insert is used, the light is set to the saved switch-on brightness when it is switched on.
... switch on the light with minimum brightness.	Press and hold the bottom of the control button.	
... make the light brighter.	Press and hold the top of the control button.	The light can be dimmed to maximum brightness.
... make the light darker.	Press and hold the bottom of the control button.	The light can be dimmed to the minimum brightness.
... adjust the brightness/raising or lowering position.	Press and hold the centre of the control button.	
... save the current brightness level as the switch-on brightness.	<ol style="list-style-type: none"> 1. Adjust the light to the desired brightness. 2. Press the top and bottom of the control button simultaneously for more than four seconds. 	The light switches off briefly and on again immediately after. The switch-on brightness is saved. If a saved brightness level is saved again, after being switched on again, the dimmer switches on at the level it was set to before switch-off.
... save a ventilation position from the upper end position.	<ol style="list-style-type: none"> 1. Press and hold the bottom of the control button. 2. Press the top and bottom of the control button simultaneously for more than four seconds. 3. Release the buttons when the desired position is reached and briefly press the button again within four seconds. 	Saving a new position overwrites the previous one (see page 85).
... set the colour temperature for DALI control devices.	<p>Operating top unit: Briefly press the top and bottom of the control button simultaneously, and this twice.</p> <p>Operating top unit, 2-gang: The right-hand control button is used to set the colour temperature directly.</p>	After the level has been set, it is saved permanently.

8.1.2 Operating top unit Memory

eNet wireless operating top unit Memory

The operating top unit Memory has the same functions as the operating top unit, but it can be upgraded to include additional functions. Both the operating top unit and the operating top units Memory offer the following functions:

1. Toggle function (On/Off) by briefly pressing on any point
2. Brightening (light) or raising (blind) by pressing and holding the left upper half of the button
3. Darkening (light) or lowering (blind) by pressing and holding the left lower half of the button
4. Save settings by pressing and holding the centre of the left-hand button

The right-hand button of the operating top unit Memory supplements the operating top unit with the disabling function (above) and the Memory function (below). By pressing and holding the blocking function for a long time, you will deactivate all automatic functions and Memory operation, and block operation of the auxiliary unit. If the blocking function is activated, however, you can still press the left half of the button manually.

Press and hold down the Memory function to activate it. In the memory function, previously saved switching operations are repeated every 24 hours.

Press the upper right and lower buttons simultaneously and activate night mode, in which both LEDs do not light up permanently, but only for five seconds.

To save the Memory function, simultaneously press the Memory button and the desired function button (On/Off, Lighter/Darker, Up/Down). Successful saving is signalled by the LED.

The eNet wireless operating top unit Memory also enables wireless operation within the eNet SMART HOME system.

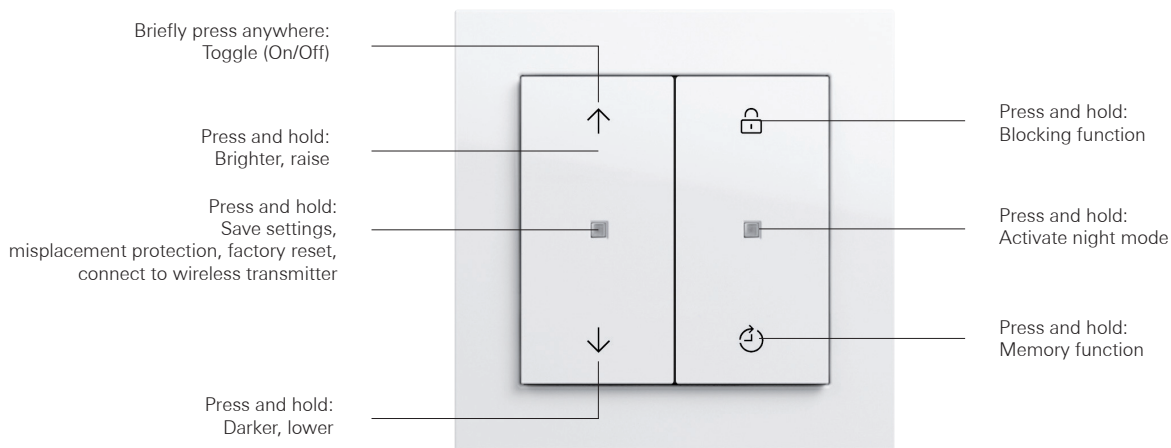

Gira operating top unit Memory
Gira eNet wireless operating top unit
Memory

You would like to ...	Implementation	Further information
... switch on the light.	Press the left-hand control button briefly.	If the dimming insert is used, the light is set to the saved switch-on brightness when it is switched on.
... switch on the light with minimum brightness.	Press and hold the bottom of the left-hand control button.	
... make the light brighter.	Press and hold the top of the left-hand control button.	The light can be dimmed to maximum brightness.
... make the light darker.	Press and hold the bottom of the left-hand control button.	The light can be dimmed to the minimum brightness.
... adjust the brightness/raising or lowering position.	Press and hold the centre of the left-hand control button.	
... save the current brightness level as the switch-on brightness.	<ol style="list-style-type: none"> 1. Adjust the light to the desired brightness. 2. Press the top and bottom of the left-hand control button simultaneously for more than four seconds. 	The light switches off briefly and on again immediately after. The switch-on brightness is saved. If a saved brightness level is saved again, after being switched on again, the dimmer switches on at the level it was set to before switch-off.
... save a ventilation position from the upper end position.	<ol style="list-style-type: none"> 1. Press and hold the bottom of the control button. 2. Press the top and bottom of the control button simultaneously for more than four seconds. 3. Release the buttons when the desired position is reached and briefly press the button again within four seconds. 	Saving a new position overwrites the previous one (see page 85).
... save the current switching time for the Memory mode.	Simultaneously press and hold down the Memory button and the desired function button (On/Off, Lighter/Darker, Up/Down).	When the LED lights up green, the current switching time is saved. Saving again overwrites the old switching time.
... delete the saved switching times.	Press the bottom of the right-hand button for more than 20 seconds until the LED lights up green a second time.	
... activate/deactivate Memory mode.	Press the bottom of the right-hand button for more than four seconds.	
... activate/deactivate the blocking function.	Press the right-hand button for more than four seconds for activation.	Manual actuation using the top and bottom of the left-hand button is still possible.
... activate/deactivate night mode.	Press the top and bottom of the right-hand button for more than four seconds for activation.	In night mode, the status and function LEDs do not light up permanently, and only for five seconds after the buttons are pressed.
... set the colour temperature for DALI control devices.	Operating top unit Memory: Briefly press the top and bottom of the control button simultaneously, and this twice.	After the level has been set, it is permanently saved.
... operate the control button on another insert with the same function.	Put the control button on another insert.	Saved settings and switching times are retained.
... operate the control button on another insert with a different function.	Press the left and right arrow button for more than four seconds.	The top unit can be operated on another insert with a different function.

8.2 Automatic control

With an automatic control with the corresponding System 3000 top units, blinds and other consumers are controlled automatically. If times have been programmed, the blinds will move and the lighting will switch on punctually by itself. This function is ideal for presence simulation, allowing home-owners to relax on holiday while blinds and lighting are controlled at set times.

The blind timer and timer display or BT or the operating top unit BT are suitable for this.

Function	Button combination
Activate blocking function	↑
Cancel blocking function	↑
Display time	ok
Display time permanently	↶ and ok
Quick save Up/On (Mon – Sun)	↑ and ok
Quick save Down/Off (Mon – Sun)	↓ and ok

8.2.1 Blind timer and timer Display



The blind timer and timer Display is a System 3000 top unit with six operating surfaces. With the arrow keys, you can control various System 3000 functions according to the insert.

Use the Menu Programming/Settings operating surface in the bottom centre to access the menu where you can select and program various functions, such as the astro function or the blocking function.

Use the OK operating surface to confirm the settings. Use the Return operating surface to undo settings and reset the changed functions to default settings.

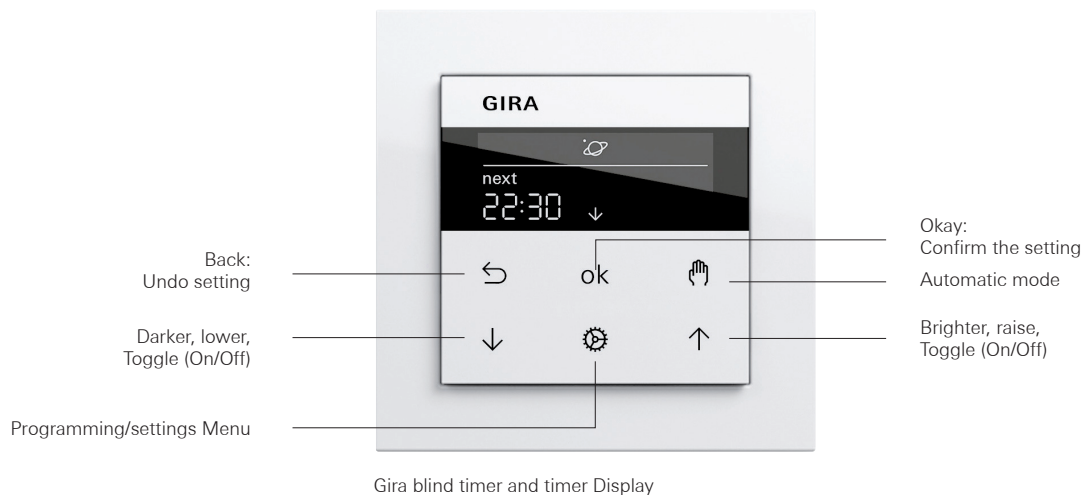
You can switch to automatic mode via the Automatic operating surface. In automatic mode, the load is automatically switched according to the saved switching times.



You would like to ...	Implementation	Further information
... switch on the lights/raise the blinds.	Press the right arrow button.	If the dimming insert is used, the light is set to the saved switch-on brightness when it is switched on.
... switch off the lights/lower the blinds.	Press the left arrow button.	
... activate/deactivate automatic mode.	Press the Automatic button.	If no times have been saved, automatic mode can not be activated.
... reset device to factory settings.	Press the Back button and the Automatic button simultaneously for more than ten seconds.	The display starts a countdown.
... permanently display the time.	Press OK and Back simultaneously for ten seconds.	Press again to switch off the display two minutes after being operated.
... save the current time as raising/lowering time.	Press the corresponding arrow button and OK for more than a second.	The time is saved for Mon – Sun and the display shows SAVE.
... activate the blocking function.	Press the right arrow button for more than four seconds.	The display shows  . Alternatively, activate the blocking function in the menu by selecting  .
... deactivate the blocking function.	Press the right arrow button briefly.	
... change the programming.	<ol style="list-style-type: none"> 1. Press the Programming/ Settings Menu button. 2. Confirm the programming by pressing the OK button. 	With blind inserts, two raising/lowering times can be programmed for each weekly block (Mon – Fri, Sat – Sun). With switching and dimming inserts, four switching times can be programmed for each weekly block (Mon – Fri; Sat – Sun).
... change the time.	<ol style="list-style-type: none"> 1. Press the Programming button and then one of the arrow buttons until the display shows . 2. Confirm by pressing the OK button and then define the settings. 3. Confirm the new time by pressing the OK button. 	In the event of a power failure, the time is retained for at least four hours.
... operate the control button on another insert with the same function.	Put the control button on another insert.	Saved settings and switching times are retained.
... operate the control button on another insert with a different function.	Press the left and right arrow button for more than four seconds.	The top unit can be operated on another insert with a different function.

8.2.2 Operating top unit BT

The operating top unit BT has a rocker (On/Off) for local operation. The toggle function (On/Off) is operated by briefly pressing the rocker at the top or bottom.

Using the Bluetooth connection, you can pair your smartphone or tablet with the operating top unit BT. The Gira System 3000 App makes full operation possible. You can conveniently access the time programmes and configuration. Both can be password protected. The values set on the device are automatically read out with the Bluetooth function as soon as a connection is set up, and are transferred to the Gira System 3000 App.

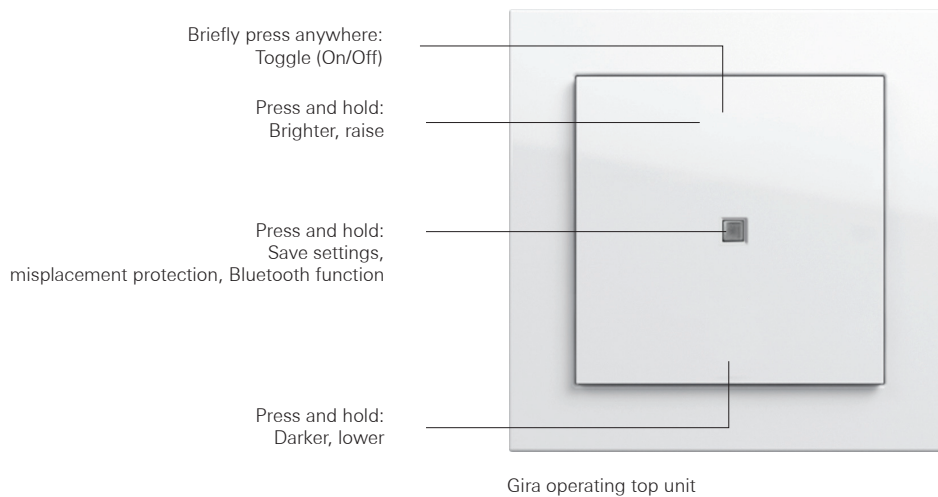

You would like to ...	Implementation	Further information
... switch on the light.	Press the control button briefly.	If the dimming insert is used, the light is set to the saved switch-on brightness when it is switched on.
... switch on the light with minimum brightness.	Press and hold the bottom of the control button.	
... make the light brighter.	Press and hold the top of the control button.	The light can be dimmed to maximum brightness.
... make the light darker.	Press and hold the bottom of the control button.	The light can be dimmed to the minimum brightness.
... adjust the brightness/raising or lowering position.	Press and hold the centre of the control button.	
... save the current brightness level as the switch-on brightness.	<ol style="list-style-type: none"> 1. Adjust the light to the desired brightness. 2. Press the top and bottom of the left-hand control button simultaneously for more than four seconds. 	<p>The light switches off briefly and on again immediately after.</p> <p>The switch-on brightness is saved. If a saved brightness level is saved again, after being switched on again, the dimmer switches on at the level it was set to before switch-off.</p>
... pair the smartphone with the top unit/Bluetooth function.	<ol style="list-style-type: none"> 1. Switch off the light. 2. Press the top and bottom of the control button simultaneously for more than four seconds. 	If you have paired your smartphone with the operating top unit BT, you can program the brightness and blind position settings using the Gira System 3000 App.
... operate the top unit on another insert with the same function.	Press the top and bottom of the control button simultaneously for more than four seconds to release the top unit.	The top unit is locked and the left LED is flashing red. It is released by pressing the buttons. The saved settings are retained.
... operate the top unit on another insert with a different function.	Press the top and bottom of the control button simultaneously for more than four seconds to release the top unit.	The top unit is locked and the left LED is flashing red. It is released by pressing the buttons. The saved settings are discarded.

8.2.3 Blind timer and timer BT

The blind timer and timer BT has four buttons (On/Off/Blocking function/Bluetooth) that control local operation. The left half of the rocker directly controls the System 3000 inserts. As with the operating top units Memory, the toggle function (On/Off) is operated by briefly pressing the left-hand button at the top and bottom. Pressing and holding the padlock icon activates the blocking function. The blocking function overrides all automatic functions and time programmes, as well as operation by means of any auxiliary units that may be connected.

Press and hold the lower right button to switch the Bluetooth function on or off. Using the Bluetooth connection, you can pair your smartphone or tablet with the blind timer and timer BT. The Gira System 3000 App makes full operation possible. You can easily access the time programmes and the configuration of the blind timer and timer BT. Both can be password protected. The values set on the device are automatically read out with the Bluetooth function as soon as a connection is set up, and are transferred to the Gira System 3000 App.

By briefly pressing the lower right button, you can deactivate automatic mode without having to hold a smartphone in your hand. This is indicated by an orange LED on the right rocker side. Another press of the button activates automatic mode again.

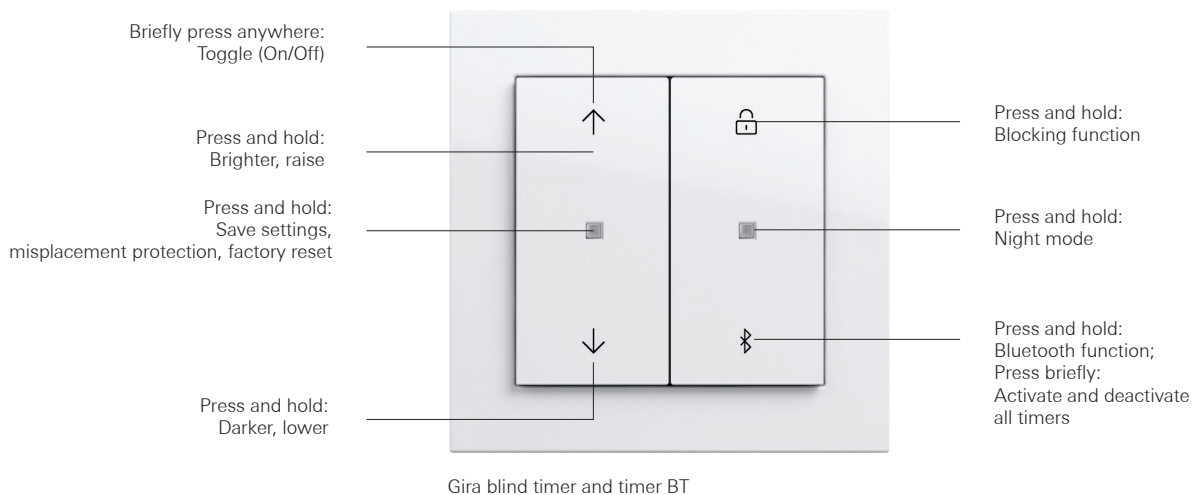

You would like to ...	Implementation	Further information
... switch on the light.	Press the control button briefly.	If the dimming insert is used, the light is set to the saved switch-on brightness when it is switched on.
... switch on the light with minimum brightness.	Press and hold the bottom of the left-hand control button.	
... make the light brighter.	Press and hold the top of the left-hand control button.	The light can be dimmed to maximum brightness.
... make the light darker.	Press and hold the bottom of the left-hand control button.	The light can be dimmed to the minimum brightness.
... adjust the brightness/raising or lowering position.	Press and hold the centre of the left-hand control button.	
... save the current brightness level as the switch-on brightness.	Adjust the light to the desired brightness. Press the top and bottom of the left-hand control button simultaneously for more than four seconds.	The light switches off briefly and on again immediately after. The switch-on brightness is saved. If a saved brightness level is saved again, after being switched on again, the dimmer switches on at the level it was set to before switch-off.
... pair the smartphone with the top unit/Bluetooth function.	Press the bottom of the right-hand button for more than four seconds.	If you have paired your smartphone with the blind timer and timer BT, you can program the brightness and blind position settings using the Gira System 3000 App.
... activate/deactivate the blocking function.	Press the top of the right-hand button for more than four seconds.	The blocking function blocks operation of the auxiliary unit and deactivates the Bluetooth function. Manual actuation using the top and bottom of the left-hand button is still possible. When the blocking function is active, the LED lights up red.
... activate/deactivate night mode.	Press the top and bottom of the right-hand control button simultaneously for more than four seconds.	In night mode, the LED lights up for a maximum of three seconds after one operation.
... operate the top unit on another insert with the same function.	Press the top and bottom of the left-hand control button simultaneously for more than four seconds to release the top unit.	The top unit is locked and the left LED is flashing red. It is released by pressing the buttons. The saved settings are retained.
... operate the top unit on another insert with a different function.	Press the top and bottom of the left-hand control button simultaneously for more than four seconds to release the top unit.	The top unit is locked and the left LED is flashing red. It is released by pressing the buttons. The saved settings are discarded.

8.4 Operation using auxiliary units

If you operate the lighting by means of auxiliary units, the following rules apply:

8.4.1 Rocker button as an auxiliary unit

The main unit is switched on by briefly pressing the button that acts as an auxiliary unit. This happens in toggle mode. If the main unit was switched off, it is switched on again by pressing the button and vice versa. If you press the button for longer, the lighting is made brighter and darker in alternation. If the minimum or maximum brightness level is reached, the dimmer stops. After each operation, the dimming direction is also changed.

8.4.2 Auxiliary unit with operating top unit

2-wire auxiliary insert

Toggle the main unit by briefly pressing the operating top unit at the top, bottom, or over the entire surface. This happens in toggle mode. If the main unit was switched off, it is switched on again by pressing the operating top unit again and vice versa.

If you press and hold the operating top unit, you can make the lighting brighter or darker and save the setting depending on where you press the operating top unit.

If you press and hold the bottom of the operating top unit, a dimming insert is switched on to the minimum brightness. If the main unit is already switched on when the bottom of the operating top unit is pressed,

the lighting is continuously dimmed down to the minimum brightness. When you release the operating top unit, the achieved brightness value is retained.

Press the operating top unit over the entire surface while the load is switched on to save the current brightness value as the new switch-on brightness in the main unit.

3-wire auxiliary insert

Pressing the top of the operating top unit specifically switches on the main unit. You can also make the lighting brighter by pressing the top of the operating top unit and darker by pressing the bottom of the operating top unit.

Moreover, you can specifically switch off the main unit if you press the bottom of the operating top unit. The 3-wire auxiliary unit with operating top unit does not feature the toggle function.

By means of selective switching (Top –On; Bottom –Off), you can use the 3-wire auxiliary unit to specifically control several main units at the same time.

8.5 Time-switch function

With the time-switch function, lighting and shading can be controlled automatically according to a set schedule. This means that lighting can be switched on or off at pre-set times or dimmed to a desired brightness level. Blinds are raised or lowered at certain times or into a set position. The time-switch function can be used with the blind timer and timer Display, operating top unit BT or blind timer and timer BT.

The top units recognise immediately whether they are fitted on a light or blind control insert and switch to timer or blind timer operation accordingly. This happens completely automatically. The changeover between summer and winter time is also automatic.

You can also set and save the switch-on brightness of dimmers. If you set certain time switching points, the dimmer switches on at the desired switch-on brightness at the time switching points that were set.

The settings are stored in a power outage safe mode, so none of the settings will be lost even in the event of a power failure.

The blind timer and timer Display splits the week into two blocks.

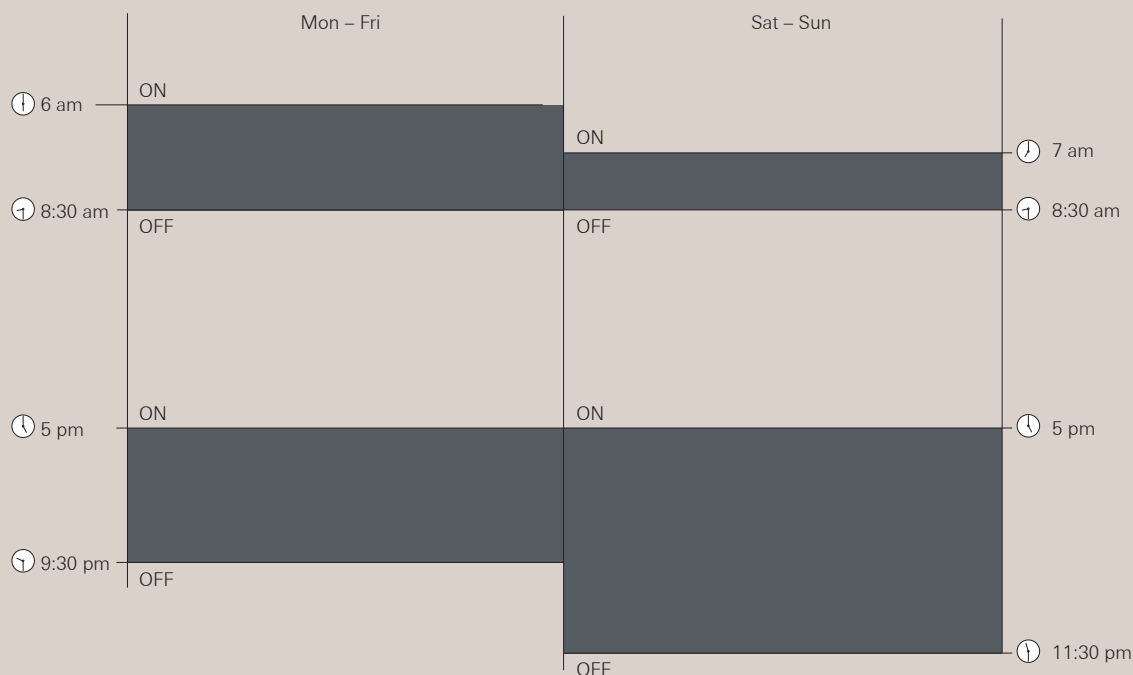

8.5.1 Switching times

The first block is Mon – Fri and the second is Sat – Sun.
For both blocks, you can program the Up/Down switching point pairs for blind inserts and the On/Off switching point pairs for switching and dimming inserts.

With the operating top unit BT and the blind timer and timer BT, you can set and manage up to 40 switching times using the Gira System 3000 App. The switching times do not have to be set chronologically but can be arranged in any order. You can program different times for each day of the week if you wish.

8.6 Astro function

Use the astro function to switch lighting and shading in accordance with sunrise and sunset. During the year, you can adjust the times for raising or lowering the blinds or for switching the light on and off according to the changing sunrise and sunset times.

Note:

To ensure that the blind timer and timer Display can calculate the astro times, you must specify the current time, date and coordinates for which the times are to be calculated. The operating top unit BT or blind timer and timer BT copy the geodata and times from your smartphone.

Example: astro function for blinds

The astro function enables a blind to be raised automatically when it gets light and lowered automatically when it gets dark. The programmed movement times limit the blind movement time. The programmed switching time in the morning is the earliest raising time and the programmed switching time in the evening is the latest lowering time for the blind.

The blind is raised at sunrise, but not before 7 am. In the evening, at sunset, the blind is lowered, but not after 9 pm.

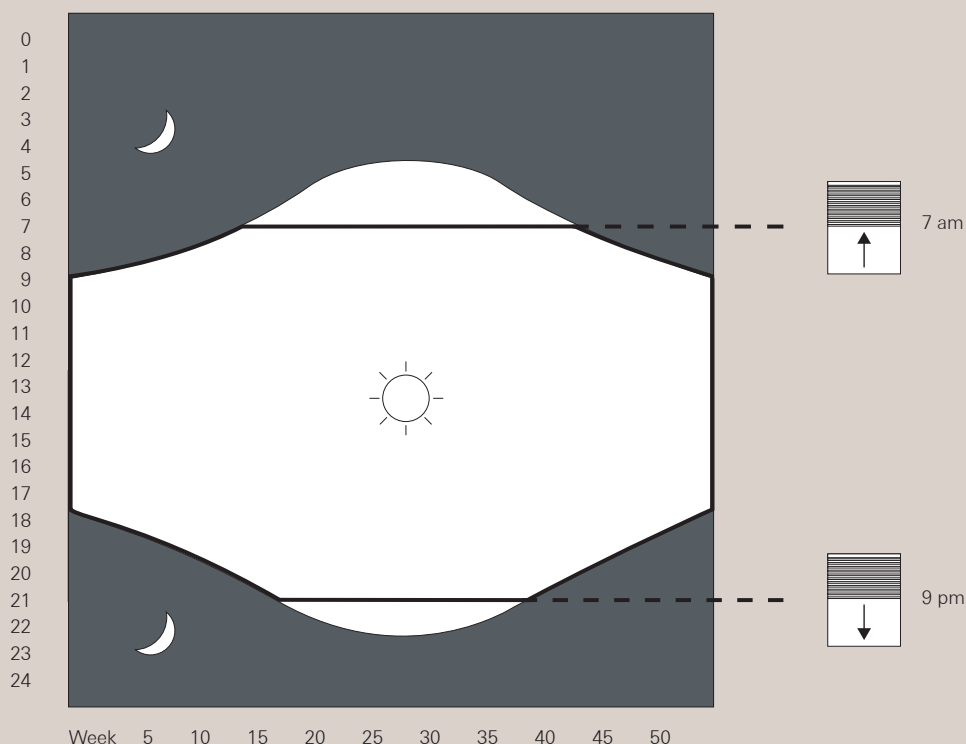

8.7 Presence simulation

If you are away for an extended period of time (for example, on holidays), presence simulation gives the impression that people are in the building and deter potential intruders. To do this, the presence simulation records switching operations and automatically replays them as required. This way, the lighting is automatically switched on even during a prolonged absence.

First, the switching operations are recorded in a defined period in recording mode. In replay mode of the presence simulation function, the recorded switching operations are replayed. If insufficient switching operations have been saved during the recording, random switching operations are carried out.

If the motion detectors detect movement in replay mode, it is evaluated and the lighting is switched accordingly. The alarm function can also be activated during presence simulation.

Note:

This function can only be activated after over 24 hours of activity were saved. In automatic mode, times during which the lighting was switched on are saved continuously. Over a period of 24 hours, a maximum of 60 switching operations are saved. If more than 60 operations occur, the oldest ones are overwritten. If the presence simulation has been activated, the lighting will be switched on at the times saved depending on the brightness. Switch-off occurs after the delay time elapses.

8.8 Alarm function

When alarm mode is activated, the motion detector switches the load to flashing mode (approx. one second on, one second off) for the set delay time. In addition, the status LED (red LED) signals that the alarm has been triggered by flashing rapidly (0.5 seconds on, 0.5 seconds off) until the alarm function is deactivated. In alarm mode, motion is evaluated regardless of brightness.

The alarm function is activated when leaving the house or apartment. If an intruder tries to gain access during this time, they will be unnerved and scared away by the sudden activation of the load. Neighbours might also be alerted through activation of the load that someone is in the house or apartment, and can call for help.

GIRA

Gira
Giersiepen GmbH & Co. KG

Dahlienstraße
42477 Radevormwald

P.O. Box 1220
42461 Radevormwald
Germany

Phone +49 2195 602-0
Fax +49 2195 602-191

www.gira.com
info@gira.com
